

NIRS Analyzer PRO



Manual
8.928.8004EN



Metrohm AG
CH-9100 Herisau
Switzerland
Phone +41 71 353 85 85
Fax +41 71 353 89 01
info@metrohm.com
www.metrohm.com

NIRS Analyzer PRO

Manual

Teachware
Metrohm AG
CH-9100 Herisau
teachware@metrohm.com

This documentation is protected by copyright. All rights reserved.

Although all the information given in this documentation has been checked with great care, errors cannot be entirely excluded. Should you notice any mistakes please send us your comments using the address given above.

Change Control

Change control on this document is as follows:

Version	Date	Summary of Changes
1.0	Dec. 2, 2012	Document first release, initiated change control

Table of contents

1	Introduction	5
1.1	Information Disclaimer.....	7
2	Hardware Familiarization	8
2.1	Lamp Housing	8
2.2	Optical Switch.....	8
2.3	Diode Array Spectrometer.....	9
3	Specifications	11
3.1	Window Reflectance	12
3.2	MicroBundle Fiber Optic Interface.....	12
3.3	Direct Light	13
4	Mounting Information	14
4.1	4.1 Mounting Frame, U-Bolts Secured to Mounting Flanges	14
4.2	Mounting by straps to blind plates	19
4.3	Weld Flange	20
5	Mounting Dimensions	22
6	Electrical Connection	23
7	Air Cooling Connection Kit	30
8	Air Purge Connection (Used with “Spoon Probe”)	32
9	Fiber Optic Probe Mounting	34
10	Ethernet Connection	35
11	Safety and Power-up	37
12	Connection to Vision Software	38
13	Diagnostics	43
13.1	Window Reflection	43
13.1.1	Performance Test	43
13.1.2	Reference Standardization	46
13.1.3	Wavelength Certification	50
13.2	MicroBundle Fiber Optic Sensing	52
13.2.1	Performance Test	52
13.2.2	Reference Standardization	55
13.2.3	Wavelength Certification	59
13.3	Direct Light Sampling	60
13.3.1	Performance Test	61
13.3.2	Reference Standardization (External Reference Correction).....	64
14	Sampling	65
15	Standards and Approvals	66

1 Introduction

Analyzer PRO is a rugged, compact Near-Infrared Process Instrument, designed for the wavelength range from 1100-1650 nanometers. This is an excellent region for process analysis, containing many second and third overtones of molecular vibrations which can be measured.

The instrument is based upon high-resolution diode array technology. The InGaAs diode array, with spectral dispersion of 1.1 nm/pixel, is a stable, intrinsically accurate method of NIR absorbance measurement. It offers excellent peak shape resolution, and contains no moving parts. Therefore, no wavelength accuracy adjustment is needed, as there is no measurable drift.



Sampling systems are as follows:

- Window Reflectance, where the sample passes in contact with the window on the side of the instrument
- Reflectance Probe, using a 1" (25.4mm) diameter stainless steel probe
- Direct Light Reflectance, where the sample passes at a distance of 4-10 inches (approximately 100-250mm) from the window

The analyzer is housed in a robust cabinet, designed for easy, reliable mounting at the desired location in the production area. Mounting is simplified by use of industry-standard stainless steel clamps, which facilitate installation and removal, as well as good positioning of the analyzer to the sample.

The instrument may be mounted in any orientation, as long as the sample window is in the proper location. The sample interface is normally placed at a point of production where the product is pumped through a pipe, dryer, blender, or other feed mechanism. There should be no (or very few) gaps or voids in the product flow, as these will cause measurement instability.

The Analyzer PRO provides non-destructive analysis of chemical and pharmaceutical products directly in the process line, without use of a bypass loop. Because most materials can be measured directly, with no need for sample dilution or preparation, the material can be measured as produced, with no loss of end product.

Operation of the Analyzer PRO is through Metrohm Vision™ software, which is robust, powerful, and easy to use. This validated software package meets all 21 CFR Part 11 requirements, and comes with a test script to prove compliance for internal regulatory personnel. Combined with normal customer procedures for network and user access, all 21 CFR Part 11 requirements are met.



Vision provides excellent tools by which to develop an analytical model for sample prediction. The NIR sample information is correlated with quantitative lab data from the primary analysis method, and a predictive model is used to report values for ongoing sample analysis.

Communication between instrument and computer is by Ethernet line, using standard connectors. Commands use a proprietary, encrypted language which is not susceptible to hacking, support of viruses, or other means of hacking. Only authorized operators may communicate with the Analyzer PRO instrument, and only by valid entry through Vision.

Measurements may be displayed in a control room area on the computer screen as they are reported in the Routine Analysis section of Vision. Provision is made for digital electronic transfer to most supported plant controller languages.

Use of the Analyzer PRO helps to optimize the use of raw materials by ongoing measurement in real time. This permits adjustment and correction of the process to target values, eliminating or minimizing waste product. The Analyzer PRO fits into Process Analytical Technology (PAT) planning, in support of recent FDA process initiatives.

Precise instrument matching enhances method development, minimizes implementation efforts, and ensures straightforward calibration model transferability between analyzers.

1.1 Information Disclaimer

This manual and the information herein are correct as of the time of publication, based upon the best information available at the time. Configuration, options, and software information may change over time, in keeping with the corporate philosophy of continuous improvement.

Metrohm NIRSystems and its distributors cannot be liable for changes to the customer process based upon information contained in this manual which is subject to revision and update. Additionally, the information and steps in this manual are not meant to serve as template standard operating procedures for use in regulation industries. Customers should supply their own procedures for internal users, based upon the specific samples, methods, and needs of the application.

Metrohm offers optional training and field support to assist in the technical aspects of calibration and library development. The final responsibility lies with the user, who has access to calibration samples, lab data, and other information required to build and maintain methods using this instrument.

2 Hardware Familiarization

Analyzer PRO is built into a rugged, sealed stainless steel housing which is designed to withstand the harsh production environment, including washdown.

Fiber optics are used with the Reflectance Probe design, and should always be protected from damage and abuse. In particular, fiber bend radius should never be less than 6" (150mm). It is strongly recommended that fibers be mounted in enclosed cable trays to minimize handling, movement, and possible accidents.

The inside view of the instrument is as shown.

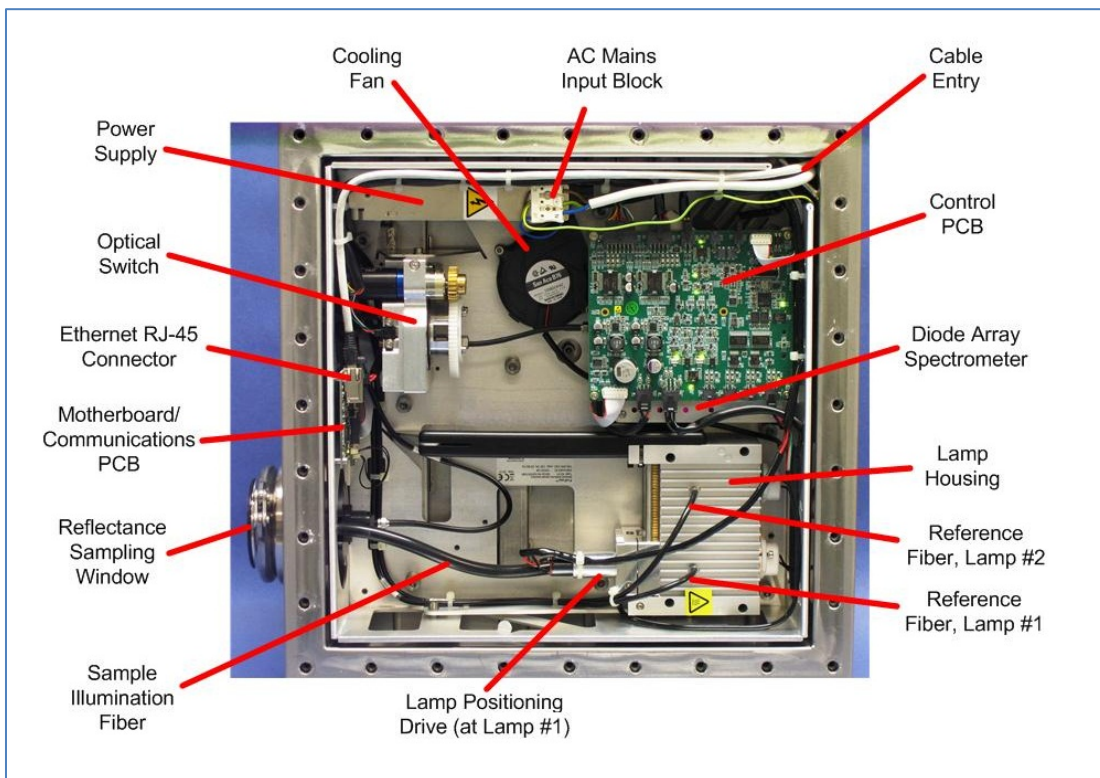

Primary components are as follows:

2.1 Lamp Housing

This contains two halogen lamps. Only one lamp is active at a time. If a lamp fails, the other is automatically switched on, and a motor moves the Sample Illumination or "light-output" fiber to the operating lamp. The Sample Illumination Fiber carries the light energy to the sampling point. Note that the Lamp Housing also has a Reference Fiber for each lamp, which are routed to the optical switch. These fibers are used to measure the background (reference) energy for each lamp. The Optical Switch automatically moves to the correct position, based upon which lamp is in use.

2.2 Optical Switch

The Optical Switch receives the light reflected back from the sample, which has been modified by interaction with the sample material. The other inputs to the Optical Switch are the two Reference fibers from Lamps #1 and #2, along with a "Dark Signal" reference. The Optical Switch, under control of the on-board electronics, measures the energy returning from the sample, compares this with the energy level sent to the sample, and scales the signal to create an absorbance spectrum over the

wavelength range from 1100-1650 nm. (The optical switch may be heard moving when instrument scans are taken, if the ambient noise level is low enough.)

2.3 Diode Array Spectrometer

The diode-array spectrometer is composed of 512 discrete InGAs detector diodes. It has no moving parts.

The wavelength accuracy is intrinsically stable, and requires no adjustment. Temperature is maintained internally to assure consistent and accurate response.

NOTE: There are no user-serviceable parts in the Diode Array Assembly. Do not attempt to open, disassemble, or service this unit. Any attempt at service or opening will immediately void the warranty.

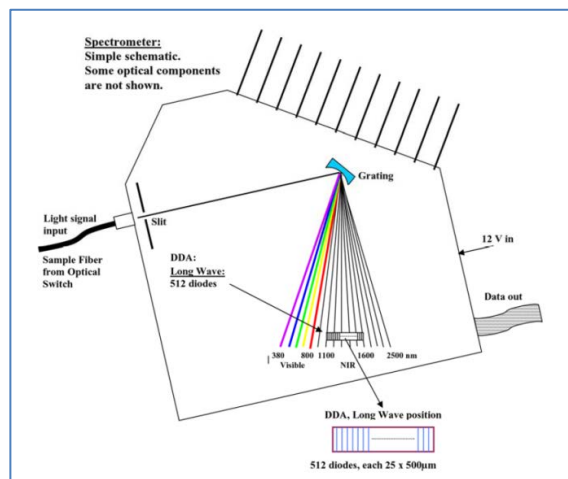

Power Supply

This takes the incoming AC Mains voltage and steps it down to 24 VDC, as used by the instrument.

Cooling Fan

The fan circulates air internally to maintain consistent, controlled temperature to the spectrometer and all internal components. This assures repeatable optical response.

Sampling Point

This may be either a Window Reflectance system (as shown here), a Fiber Optic Probe, or Direct Light. The internal instrument interface is the same for all styles. A fiber optic bundle carries the light to the sample. A small bundle carries the returning energy from the sample to the Optical Switch.

AC Mains Block

This is explained in the section on electrical Connection. All connections should be made in compliance with local codes, by a qualified electrician. Always use safety lockout procedures when performing electrical wiring.

Ethernet RJ-45 Connector

The Ethernet cable is plugged in on the instrument motherboard.

Control PCB

Instrument functions are controlled from this PC board. There are no user-serviceable items or procedures in connection with this board.

Block Diagram

The internal light paths of the Analyzer PRO are shown.

The sample is illuminated with white light. The resulting signal is sent back (through the optical switch) to the Diode Array Spectrometer for analysis.

Both dark and light reference signals are used to set the scale of absorbance. Vision uses the resulting information to produce sample spectra. The formula (shown only for information) is as follows:

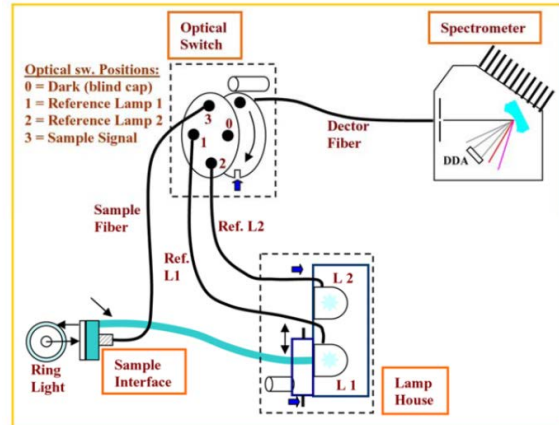

$$A \rightarrow -\log_{10} \frac{\text{Sample spectrum (3)} - \text{Dark Spectrum (4)}}{\text{Reference spectrum (1)} - \text{Dark spectrum (2)}} = \text{Absorbance Spectrum}$$

3 Specifications

Overall Analyzer PRO instrument specifications are as follows:

Item	Specification
Ambient Temperature	23 to 104° F (-5 to 40° C) With Air Cooling: 23 to 149° F (-5 to 65° C)
Ambient Humidity	10-90% Relative Humidity, non-condensing
Electrical Supply	100-240 VAC, 50-60 Hz, 2.0 A, 150 W
Protection	IP69k according to IEC 60529 and DIN 40050 part 9, NT ELEC 023
Dimensions	Width: 17.0" (42 cm) Height: 17.0" (42 cm) Depth: 5.0" (13 cm)
Weight	33.0 pounds (15 Kg)
Pressurized Air Cooling (Ambient Temperature 45-65 Degrees C)	Cooling air flow rate minimum 5 Liters/min >99.9% water free >99.9% free of oil and fine particles down to 0.3 micrometers
Pressurized Air – Spoon Probe	Purge air: 3-5 bar
Network Connections	Local Area Network (LAN) – Ethernet, RJ-45 connection
Sample Temperature, Reflectance Window	302 degrees F (150° C)
Sample Temperature, Spoon Probe	248 degrees F (120° C)
Computer Requirements	See Vision computer requirements
Wavelength Range	1100-1650 nm
Analysis Time:	5 – 50 ms / integration time; depends upon sample. Typical result time: 3-15 sec.
Wavelength Accuracy	0.5 nm
Wavelength Precision	< 0.02 nm
Wavelength Stability	< 0.01 nm/°C

Specifications for each type of sample interface follow:

3.1 Window Reflectance

In-line analysis of paste, granulates, slurry, powdered products and similar materials in pipes or fluid transport systems can be performed without need for bypass streams. The sample material must pass over the sample interface window.

The window reflection interface may easily be installed into the production line using standard GEA Tuchenhausen flowcell mountings, or by welding an interface flange into the wall of the pipe/transport system. GEA Tuchenhausen is well known for innovative, hygienic components for operation in the process stream.

- Temperature: 150°C (302°F)
- Pressure: Vacuum > 1 Torr (approximately 1 mm Hg), Pressure < 3000 PSI
- Lens: Sapphire; diameter 45 mm (1.8"), thickness 12 mm (0.5"), with EPDM O-ring seal for reliable, temperature resistant sealing
- Pipe flowcells: Fits directly into GEA Tuchenhausen Varinline Access units (DN40 to DN150 with 68 mm [2.7"] opening). This mounting method facilitates implementation of CIP (clean in place) and SIP (sterilize in place) methods.
- Transport System: Stainless steel welding flange

3.2 MicroBundle Fiber Optic Interface

Direct in-line measurement with microbundle fiber optic probe interface, optimized for process streams of clear to opaque liquids, slurries, suspensions, and powders. The analyzer may be configured with a reflectance or immersion probe based upon sample type.

316 Stainless Steel or Hastalloy Probes (custom materials also available)

- Micro Interactance Reflectance Probe
- Micro Interactance Immersion Probe
- Micro Interactance Reflectance with purge on collection tip (requires clean air or nitrogen for purge)
- Optimized Micro Reflectance (45-degree) Probe with 3 meters of fiber (Angled face for optimized sample collection)

Window: Sapphire

Temperature: 300°C (572°F)

Pressure: 5000 PSI (344 Bar)

Diameter: 1" (25.4 mm) Standard

Length: 12" (305 mm) Standard

Installation: 1" Swagelok® crimp fitting

Cleaning: Wash in water, hot or cold depending upon product

Fiber: Interactance Micro Fiber Optic Bundle (3m) with Metal or Nylon Cladding, SMA connection to the Analyzer PRO

3.3 Direct Light

In-line analysis of products where direct contact with the product is not technically feasible, such as product transported on a conveyor belt or similar means of movement.

Lens: Sapphire; diameter 45 mm (1.8"), thickness 12 mm (0.5"), with EPDM O-ring seal for reliable, temperature resistant sealing

Distance: 100-250 mm to sample surface (4 to 10")

Scanning Area: 20 - 85 mm (0.8 to 3.3") diameter, depending upon distance to sample

4 Mounting Information

Analyzer PRO is provided with an innovative, rugged integral flange-mounting system that permits easy installation and service. There are two mounting flanges, top and bottom, to which are mounted “blind plates” using a rugged, industry-standard tri-clamping mechanism. This approach eliminates bolt holes or other entry points for contaminants.

The mounting flanges are sized to attach directly to 3” (76.2 mm) diameter stainless steel piping, which is widely used in sanitary installation areas. To mount using pipe, determine where the window or fiber will be positioned, and install pipes in the corresponding positions for supporting and mounting the enclosure. The pipes should have the proper flange ends to accept the clamps to lock the Analyzer PRO instrument in place.

Two alternative methods are shown. This first is preferred in most cases.

4.1 4.1 Mounting Frame, U-Bolts Secured to Mounting Flanges

Many installations will be performed using a fabricated mounting frame which can be bolted to a solid surface in the plant. This mounting method should be well-planned, so the sample window (or fiber optic probe) is in the right location upon final installation. In this case a Analyzer PRO Fiber Optic Probe system is being installed.

This sequence shows mounting the frame to the Analyzer PRO instrument first, then bolting the frame (with Analyzer PRO installed) to the mounting bolts.

We advise using a cart or frame to support the instrument during mounting, to avoid damage. Use lab jacks as shown, to make height adjustment easy. Protect the fiber optic cable, as well as the power and communications cables. Do not kink, bend, or otherwise stress the fiber optic cable in any way, as this may damage the internal fibers and cause loss of energy.

Safety **NOTE:** Please follow all site safety rules regarding lifting and physical exertion while mounting the Analyzer PRO.

In addition, use of a rolling cart provides an easy way to protect the fiber optic cable, power cable, and communications cable – they are carefully coiled on the lower shelf of the cart, to avoid damage.

1. Remove the locking clamps and blind mounting plate from each mounting flange. Remove the gasket as well.

Keep all these parts in a safe place, in case they are needed at some point in the future.



2. Fabricate the mounting frame as shown. It may be larger if required. In this installation we purchased pre-cut channel from McMaster Carr. We used four (4) lengths of Steel Strut Channel, Slotted, 1-5/8" x 1-5/8", zinc-plated, 2 foot length, part number 3310T53.

The brackets each measure 24" (610 mm) in length. The upright brackets are bolted so the centerline of the slotted holes is 17.25" (about 439 mm) apart. Use 3/8" (or 10mm) bolts.

The brackets should be capable of supporting the full Analyzer PRO weight, plus an ample safety margin. We suggest a minimum capacity be 100 pounds, or roughly 45 kilograms.

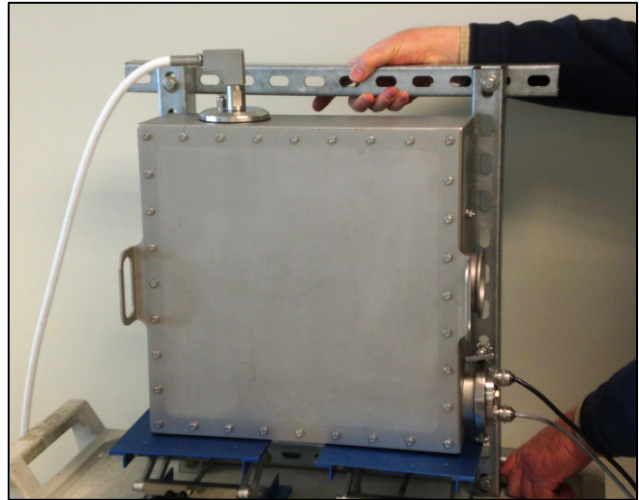

Note that the Analyzer PRO instrument is on a cart for positioning. We use lab jacks to raise it to the final mounting height, to avoid difficult lifting. The installer is shown checking the size and slot pattern for fit.

3. Use 3" (76.2 mm) inside-diameter stainless U-Bolts with extended-length legs, like that shown.

(This is a McMaster-Carr Extended-Length Type 316 SS U-Bolt 3/8"-16 Thread, part number 29605T7 -- as of time of publication.)

Remove the nuts from the U-Bolt and gently place it over the flange as shown. Verify that the mounting height is correct, and that the U-Bolt will be in the correct position to bolt onto the brackets. Use additional wooden blocks to reach the proper mounting height. Check both sides.



4. Adjust height with the lab jacks, so the U-Bolts align properly with the frame slots. Adjust each side equally, to keep the Analyzer PRO aligned with the bracket.

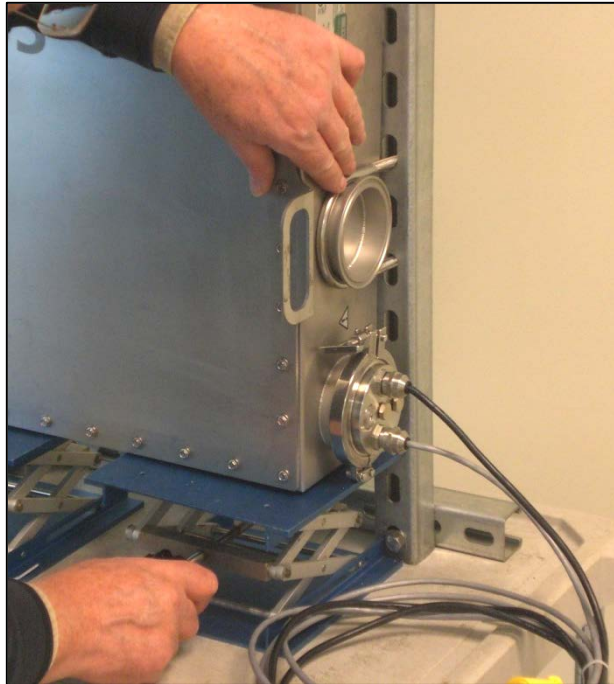

5. When the height is correct, push the U-Bolt through the slots.

Do this on both sides of the Analyzer PRO instrument, in preparation for securing with washers and nuts.



6. Install large washers, lock washers, and nuts on the ends of the U-Bolts. Do not tighten until all four sets of washers and nuts are in place.

When all four sets of hardware are in place, gently tighten each nut, using care not to distort the U-Bolts or frame.

If preferred, nylon-insert locking nuts may be used in place of normal lock washers and hex nuts.



7. The Analyzer PRO instrument is now securely mounted to the fabricated frame. It is ready to be mounted to the final process location.

Verify that all hardware is secure. Protect the fiber (if so equipped) as well as the power and communications cables.

Carefully move the Analyzer PRO instrument and mounting frame to the final location.

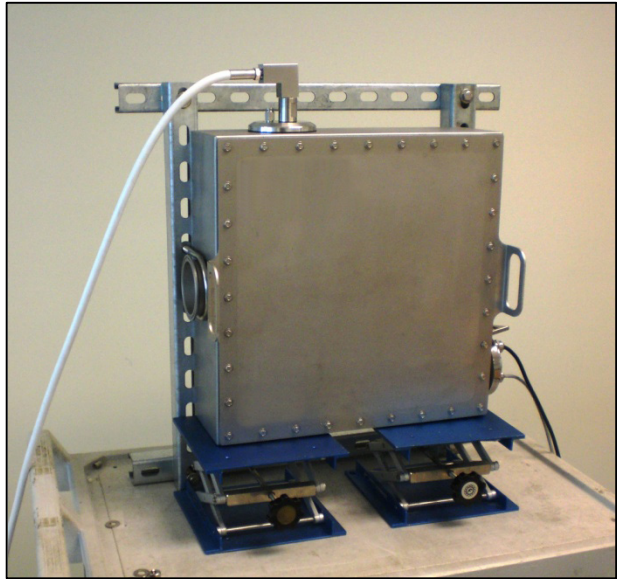

8. Mounting studs should be placed in the correct positions to hold the frame in place.

We installed 3/8" studs in the mounting area as shown. These are 21.75" (552mm) apart, which corresponds with the slot holes in our mounting frame. The lower studs are mounted 22" (560mm) below, at the same width.

These studs should be capable of supporting the weight of the Analyzer PRO instrument and frame, with a large margin of safety. Be sure to measure for the frame used, and



9. Roll the cart so the mounting frame is directly in front of the mounting studs.

Using the lab jacks, raise the Analyzer PRO instrument (on the mounting frame as shown) to the correct position. When the studs align with the mounting frame, gently ease the mounting frame over the studs as shown.



10. Install a large washer, a lock washer, and a hex nut onto each stud.

Do not tighten until all four sets of hardware are in place.

Continue to protect the fiber optic cable, as shown here.



11. When all four sets of washers and nuts are threaded on, begin tightening each set. Do not damage or distort the mounting frame.

If nylon-insert nuts are preferred, those may be used in place of standard hex nuts.



12. When all hardware is tight, the lab jacks may be lowered and removed. This may be done gently, to verify that the mountings support the weight, and that all hardware is properly tightened.

This photo shows the final mounting, with all bolts installed and tightened.

As before, continue to protect the fiber optic cable, as well as the power and communications cables. The cart is still shown at the bottom of this photo, immediately after removing lab jacks. The cables are on the bottom shelf, ready for the next stages of installation.

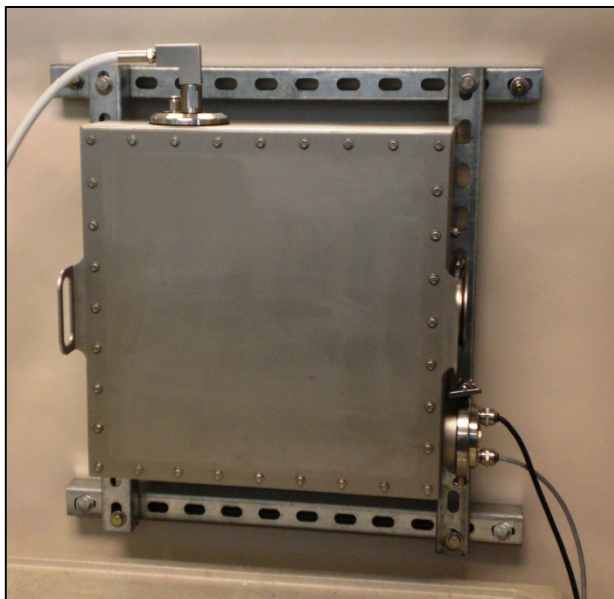

4.2 Mounting by straps to blind plates

The blind plates are 15mm stainless steel, and are equipped with a special gasket to properly affix the blind plate to the flange on the instrument.

The blind plates may be welded or machined in any way to properly affix and support the instrument in the desired position.

Do not distort or weaken the blind plates, as they support the full weight of the Analyzer PRO. Weight is 33 pounds, or 15 Kg.

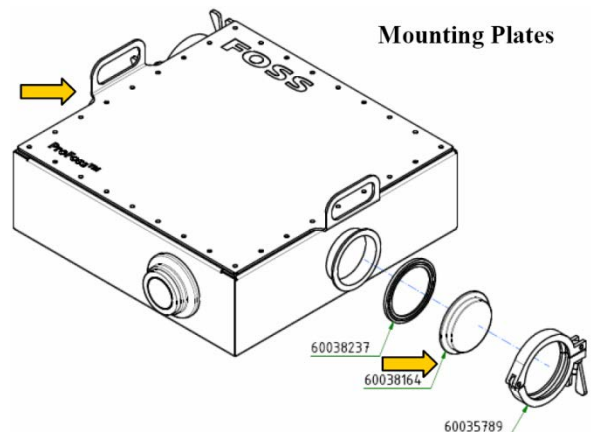

The mounting flange of the instrument is shown at the top.

The "blind plate" and gasket are shown at right.

The clamp is a "Tri-Clover" style. It is an ISO Clamp, 76.1mm. This style of clamp is used in sanitary installations, and is known for ruggedness as well as ease of installation and removal.

Do not attempt to drill mounting holes through the cabinet or cover, as this will compromise the protective sealing of the instrument enclosure. Any holes drilled in the cabinet will invalidate the instrument warranty.



Before mounting, determine the optimal desired position of the sampling window, and arrange for the blind plate positions to correspond to that desired sampling position. (With a fiber optic probe this position may be less critical.)

Before mounting the instrument, verify that the blind plates are in the correct locations, and that the fabricated mounting arrangement will support the full weight of the instrument. When mounted, the distance from the outside flat of the top blind plate, to the outside flat of the bottom blind plate is 19.25" (384mm). Leave some provision for movement of the mounting brackets (such as slotted holes) to ease mounting and final positioning. At least ¼" (6mm) of movement is recommended. The gaskets have a molded ridge on each surface, and the mounting must accommodate this ridge during assembly.

The blind plate, gasket, and mounting flange should be securely clamped in place, top and bottom. There should be no play in the clamp or mounting mechanism. This method of mounting provides for easy mounting and dismounting, if required. The cover, secured by 32 bolts and sealed by a compressive gasket, has two handles which allow lifting. Please wear protective gloves when lifting.

This photo shows one installation on a process pipe.

The Analyzer PRO instrument is supported by metal straps from a support above the instrument, using the mounting flanges. In this case the blind plates were drilled to accept the mounting bolt. Because the mounting flange openings are sealed, there is no risk of contaminants getting inside the Analyzer PRO enclosure.



This photo was taken before the cables were secured with tie wraps.

When the mounting is finished, secure the power cable and communications cable to prevent damage. Be careful where they exit the Analyzer PRO, as a very tight bend here may cause cable damage. It is wist to protect the cables from any passing traffic or possbile impact.

4.3 Weld Flange

The Weld Flange may be used to mount the instrument to ports where sample material is moving in a continuous manner, and sampling will be consistent. Additional supports using the mounting plates are required to hold the weight of the Analyzer PRO. While this flange may be welded, many customers prefer to bolt it in place. Either method is acceptable, as long as sampling is not impeded.

The Weld flange uses the standard sanitary sample interface and offers a large diameter surface that can be welded onto the process. The Analyzer PRO is then connected to this flange.

Additional supports using the mounting plates are required to hold the weight of the Analyzer PRO.

Sample windows must be clean before final installation.



This photo shows an installation on a chute, where the product falls by gravity onto the sample window, thus providing a suitable measurement.

The Weld Flange is bolted to a plate which mounts in the duct. The plate may be removed if needed, and replaced with a blank plate. This allows cleaning and minor maintenance, without stopping the line for more than a brief interval.

Note that the Analyzer PRO is supported by straps on each side, which support the weight. The Weld Flange does not support the weight of the instrument.

This shows the weld flange mounted on the Analyzer PRO. The Tri-clamp is used to secure the instrument in place on the weld flange.

NOTE: The Weld Flange provides positioning of the sample window only. It does not support the weight of the Analyzer PRO instrument.

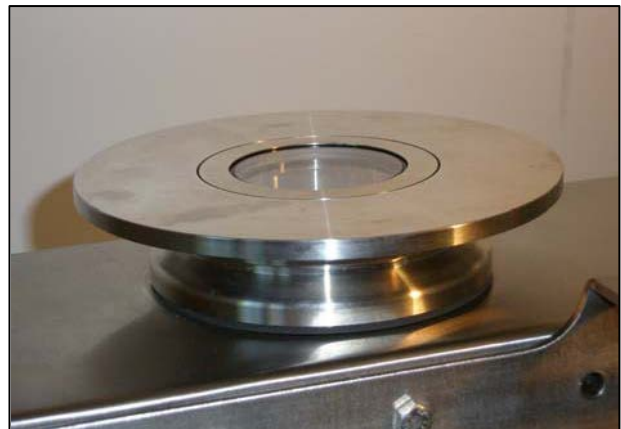

5 Mounting Dimensions

The Analyzer PRO dimensions are as shown. Note that the dimensions are in "hard Metric". The inch conversions are very close, but will be less exact.

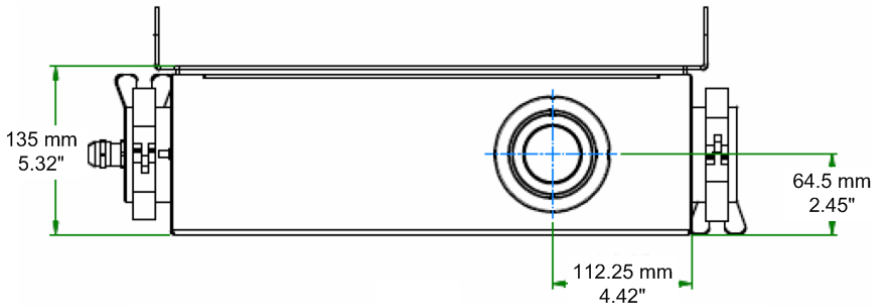

This view shows the distance to the viewing window, as measured from the side.

Note the mounting flanges shown on either side of the drawing – these are detailed below.

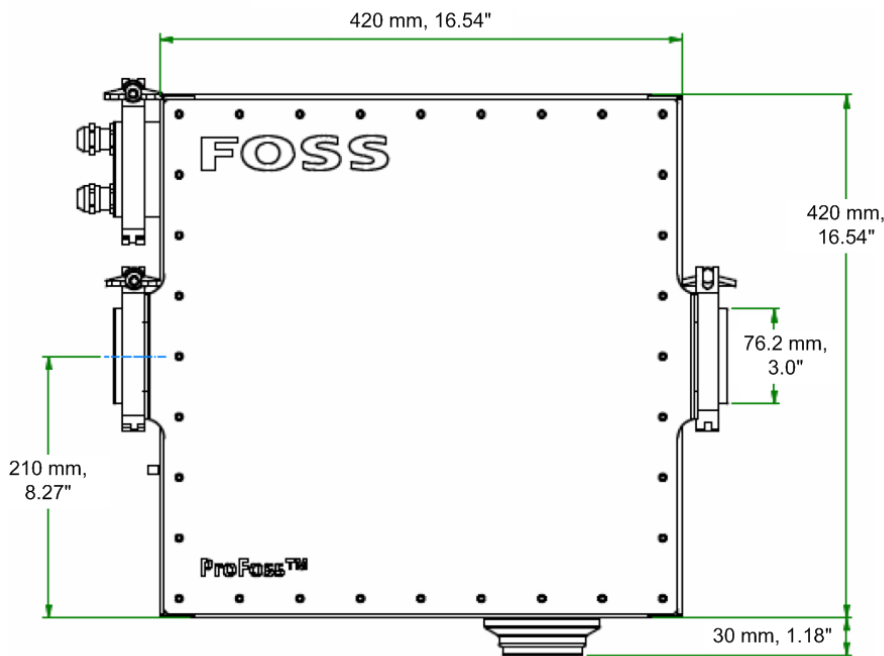

The front view shows overall dimensions, as well as the height to each flange.

The critical dimensions are those to the sampling point – the sample window must be in the correct position to take spectra of the sample.

Be sure to leave room for electrical connection.

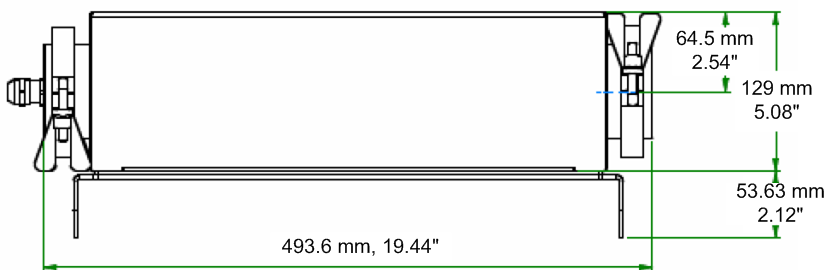

Flange mounting dimensions are shown. Leave room for attachment of Tri-clamps by installation personnel.

6 Electrical Connection

The Analyzer PRO is shipped with a temporary AC mains electrical cable in place, suitable for initial testing. Cord length is just over two meters. The installer need only terminate the AC mains power cable as required to meet local codes and installation requirements.

For permanent installation, a suitable cable must be installed. This cable should be three-conductor, round cross-section, 3.0mm nominal diameter, and must meet all electrical, temperature, and installation requirements for the area where mounting will be performed.

The electrical connector flange also uses a removable plate and quick connect clamp. The plate has two cable entry glands for the power line and the other for the LAN cable.

The instrument is supplied with fitted cables for both with 3 meters length enabling the Analyzer PRO to be installed easily in a laboratory environment for start-up training on the operation of the analyzer.

An additional two plugged threaded holes (G1/8 thread) are present on the plate for the addition of the air cooling kit.

An illuminated button is also present. Functions will be discussed.



Electrical specifications are as follows:

Electrical Supply	100-240 VAC, 50-60 Hz, 2.0 A, 150 W
Protection	IP69k according to IEC 60529 and DIN 40050 part 9, NT ELEC 023

Connections are marked as follows:

Symbol	Meaning	N. America	Europe
L	Line	White	Brown
\perp	Ground	Green	Green/ Yellow
N	Neutral	Black	Blue

AC Mains connections and Ethernet Connection enter the Analyzer PRO through the fitting shown. This fitting provides for gasketed, sealed entry of cables.

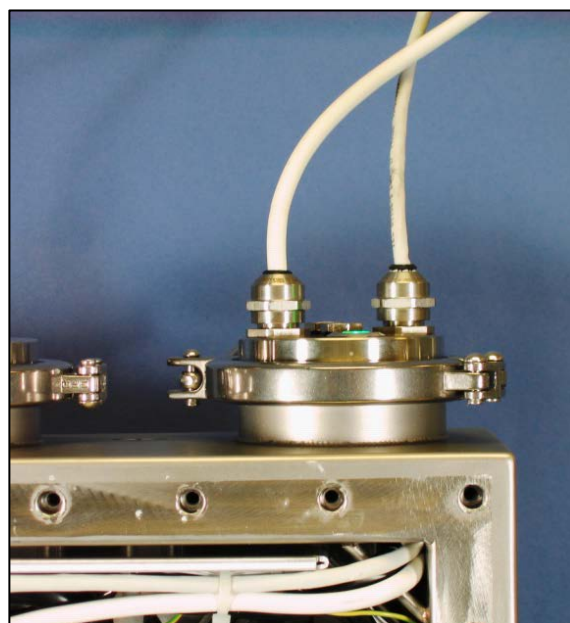

The cables have round cross-section to assure good sealing in the clamping ferrules. When the AC

mains cable is replaced, the same type of cross-section of cable must be used to assure a good seal. The cables are carefully routed to prevent interference with operation of the Analyzer PRO.

When replacing the temporary AC mains cable, follow this procedure:

1. Remove power from the instrument.
Both poles must be broken.
Use safety lock-out procedures if applicable.



2. Unplug or disconnect existing, temporary AC mains cable.



3. Remove the 32 screws holding the cover in place on the instrument. Use a 7 mm socket or nut driver.

NOTE: If using a powered removal tool, set the torque on a low setting, to avoid stressing the screws. Start at a low torque, then increase enough to remove the screws easily. Use a similar torque when re-installing the screws. Avoid cross-threading.



4. Press each tab above the wire to be removed, and pull the wire directly outward.

NOTE: Verify that power is off before performing this operation.

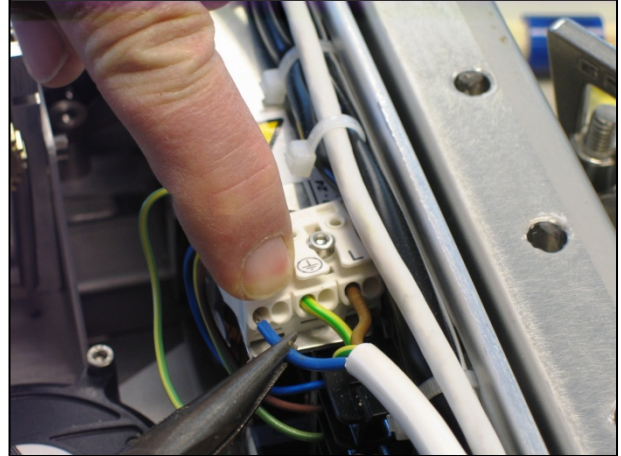

5. Gently loosen the cable gland over the existing AC mains cable. Use a 22 mm (approx 7/8") open-end wrench.

NOTE: This nut is easy to loosen before removal of Tri-clamp. Do not fully remove the nut at this point.



6. Remove the Tri-clamp holding the cable input header. Save clamp for re-use.

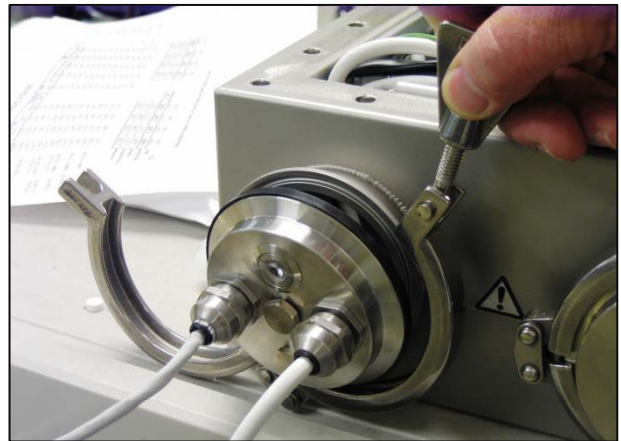

7. Continue to loosen the gland nut until it separates from the cable seal.



8. Slide the gland nut and sealing ferrule back from the threaded area.



9. Prepare a "fish" line which will be used to pull the new cable into the enclosure.
This line will be used to pull the new cable back into the correct position.

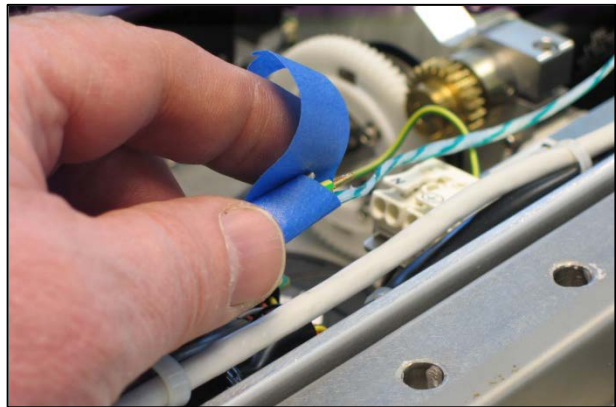

10. Gently pull the old cable out of the threaded header, guiding the fish line as needed.
Do not pull the line all the way out – the far end should remain where it can be used to pull the new line into the instrument enclosure.
This view shows the fish line after pulling. Remove tape and old cable.

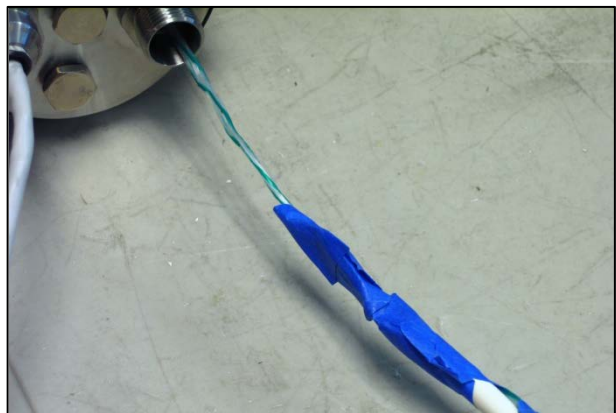

11. Note the position of the nut, seal and o-ring on the existing cable. Remove each one and prepare to install on the new cable.



12. Install the parts as shown on the new cable. This cable is a "North American" type of cable, with white, black and green conductors.



13. Secure the new cable to the fish line, and prepare to gently pull the new cable into the instrument.

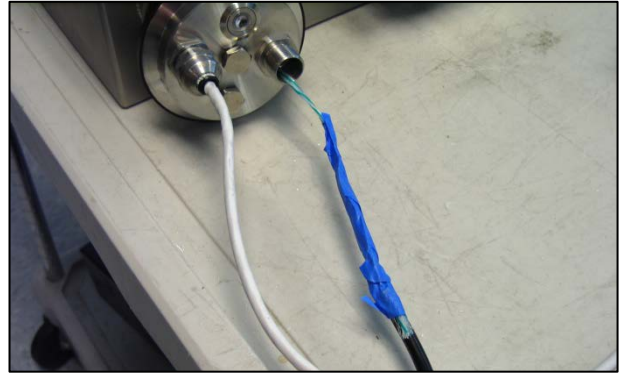

14. Pull the fish line inside the instrument, while feeding the new cable gently through the threaded opening, and up through the corner of the instrument cabinet.

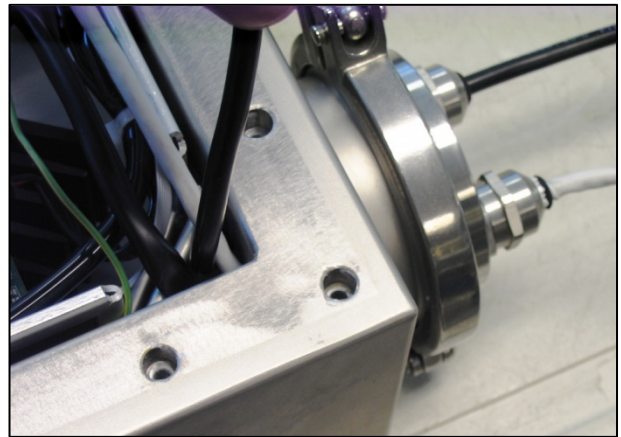

15. Run the new cable to the AC power block. Push down on each tab and install the correct wires as shown, all the way into the aperture.

After installation, give each wire a gentle tug to assure that it is seated properly. If the cable "pulls out", verify that the cable end is not distorted, and try again.

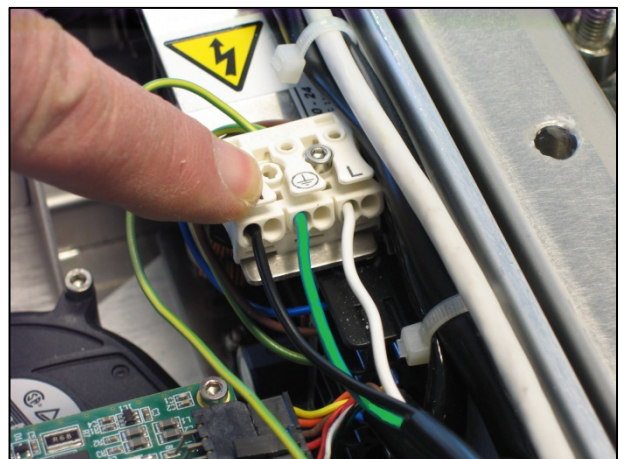

16. Be sure the black o-ring is installed into the groove on the sealing ring as shown.



17. Thread the gland nut and hand-tighten.



18. Using the same 22 mm wrench, tighten the gland nut to compress the seal properly. Do not crush the cable. When tight, the cable should not "give" when tugged slightly.



19. Tie-wrap the new cable to the Ethernet cable internally, to secure it from moving under vibration. Cut off the loose end.

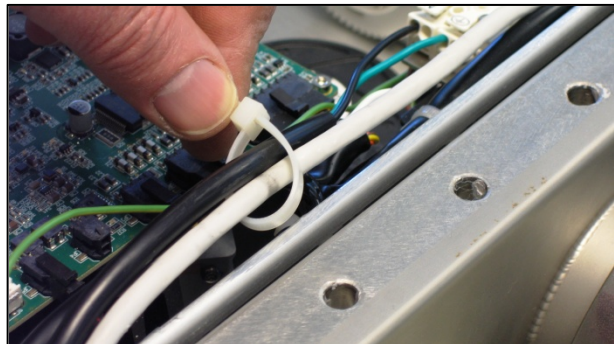

20. If not using a “fish”, the wire can be fed directly. Note that the cable is fed through a corner of the mounting enclosure, and is easier to feed in one direction than the other.

We recommend feeding the new AC mains cable through the triangular corner opening – and then into the large round opening -- where it can easily be located and pulled through.

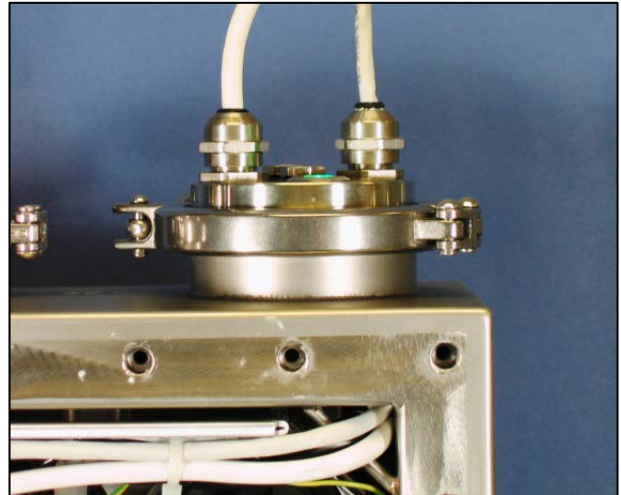

The AC Mains connection point is shown, with European color coding. Always follow all applicable local codes to assure safe, reliable connection.

As a reminder, connections are as follows:

Symbol	Meaning	N. America	Europe
L	Line	White	Brown
\perp	Ground	Green	Green/ Yellow
N	Neutral	Black	Blue

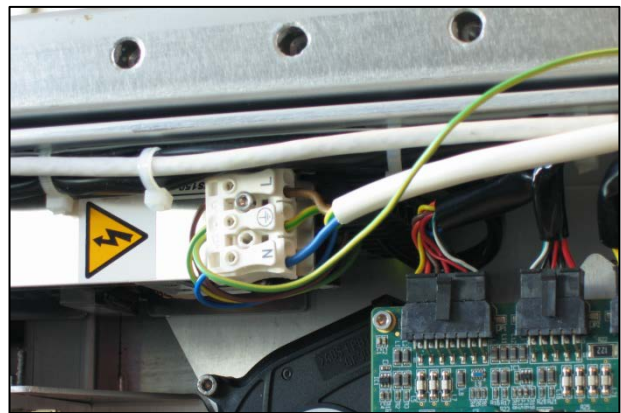

When complete, check all connections and seals. Check power to be sure it operates properly. Re-install instrument cover.

This photo shows a close-up view of the wiring entry point.

Note the LED on the flange. This LED is not related to AC power.

This LED will be steady green (not blinking) when the instrument is ready. When scanning, the LED will blink green. This will also be mentioned in the sampling section of this manual.



7 Air Cooling Connection Kit

Compressed Air Cooling Kit (60038416), installation

The optional air cooling kit for high ambient temperatures over 45 °C includes quick-connect fittings that are placed in the two plugged holes. Tubing is also supplied, along with an air filter set with regulator to remove water and oil from the compressed air supply.

Adjust the air supply volume until the temperature is below this value

This kit includes three Air Fittings, a 30 cm (11.8 inch) piece of air tubing, and 20 m (65 feet) of extra tubing.

Preparation for Installation:

1. Loosen the tri clamp and pull out the round plate with the two blind plugs.
2. Remove the two blind plugs and mount the air fittings instead.
3. Mount the third air fitting on the inside of the plate. Use the hole closest to the bottom of the cabinet. This is now the air input.
4. Some of the first kits included a Silencer (Ceramic cylinder on a short brass tube) for the exhaust. This must NOT be mounted; it may cause a too high pressure inside the box.

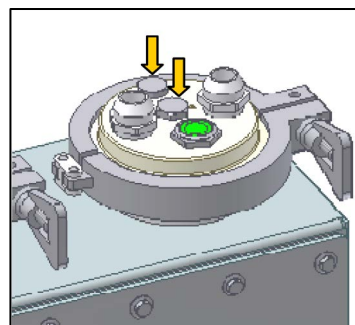

Mounting the air tubing:

5. Cut the tube to length with a clean cut.
6. Push the end of the tube into the fitting until it makes a tight seal.
7. To remove the tube, press down the collar of the fitting while gently pulling the tube.



Connecting the units:

8. Mount the 30 cm tube in the air input fitting on the inside of the round plate. Lead it into the instrument, under the Mounting Tray so that the outlet is close to the opposite wall. If needed, adjust the length of the tube.
9. Mount the plate on the instrument again, and tighten the Tri-clamp.
10. Mount a suitable length of tubing to the air out (exhaust) air fitting on the Analyzer PRO. Lead the tube to terminate at a point where the exhaust flow of air is not objectionable to nearby personnel.
11. ATEX rated areas may require termination of the exhaust tube to another room or outside. Check with the customer's Safety personnel, or the on-site ATEX-responsible person.
12. Mount a tube from the regulator to the air input on the Analyzer PRO.

13. Pull the knob on the regulator and turn it fully counter clockwise in order to set the pressure to zero.
14. Connect the factory air to the water separator.
15. Slowly increase the pressure until a smooth flow is felt from the exhaust tube.

Normally a setting of app. 0.02 MPa (0.2 bar) is about right. The objective is to keep the temperature somewhat below 65 °C.

8 Air Purge Connection (Used with "Spoon Probe")

Air purge may be used with the MicroBundle "Spoon Probe" which uses air purging to remove accumulated sample from the window area, under control of the software.

Part number 60039031 must be used. Install the kit as explained above. The Analyzer PRO MicroBundle Fiber version comes with the solenoid air control valve and fittings already mounted. Connect the output from the regulator to the air input on the instrument.

One way valves are mounted in the air in and air out connections inside the instrument: Observe the "in" and "out" arrow marks next to the fittings.

1. Connect the air tube from the powder probe to the air out fitting.
2. Connect the air from the regulator to the air in fitting.

Adjust the pressure for effective emptying of the spoon after measurement. Pressure range 0,3 – 0,5 MPa (3 – 5 bar, 43.5 to 72.5 PSI).

The probe is designed for a standard 1" Swagelok® crimp fitting.

The "Spoon Probe" is typically used in fluid bed dryers and other locations where sample is conveyed in a manner where it may accumulate on the probe and be sampled periodically.

After sampling, purge air is activated through the purge holes, and the sample is cleared from the sampling area, in preparation for the next sample.



The air inlet at the base of the probe is shown. The fitting is a ¼" NPT Swagelok SS-400-1-1 fitting, or equivalent. (Qty. 1)

It is critical to remember that the supply lines must be sized much larger than the final deliver line to the probe. Internal friction on a long supply line will limit the amount of gas available to the probe, if the line is too small. The tubing to the probe itself is ¼" (about 6mm) however the supply lines may have to be much larger to accommodate the full flow required.



A ground ring is provided, as samples may build up static electricity. The probe should be properly grounded using this ring.

This photo shows a typical accumulation of sample on the face of the spoon probe. This photo was taken in a fluid bed dryer, in between purge cycles.

As sample accumulates, the instrument will take a sample scan and produce sample spectra for analysis. The scan timing must sometimes be adjusted to the flow rate, to assure that enough sample has accumulated.

When the purge air system is activated, the pressure through the purge holes “blasts” the sample from the face of the probe. While a slight film may be left on the probe window, this is not enough to skew spectra, and can be ignored.

The photo shows the internal control for the air purge. This valve is controlled by Vision. A setup screen allows setting of intervals and timing. This shows a typical setup, though yours will vary.

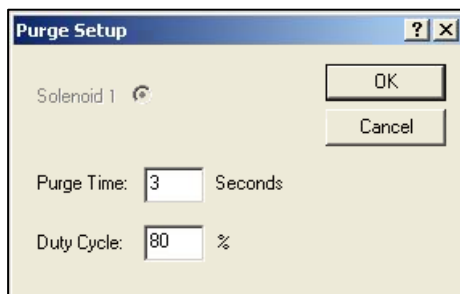

IMPORTANT NOTE:

The purge gas provided to the probe must be instrument grade, to avoid coating the probe window with foreign substances.

Specifically, if air is provided, it should be from an “oil-less” source, and should be clean, dry, and filtered. “Instrument-grade” air, or pure nitrogen, are two possible types of purge gas that may be used.

The user is responsible for chemical compatibility with the process, cleanliness of the purge gas, temperature variation, pressure, and control over flow.



9 Fiber Optic Probe Mounting

The MicroBundle fiber optic probe will come installed to the Analyzer PRO. It will be tested in the final configuration, to assure good operation.

It is very important to protect the fiber optic cable, to prevent damage. While the cable can be replaced, this is quite expensive and should be avoided. Careful mounting and handling are important. Never let a fiber optic cable hang where it can be snagged by equipment, crushed, or otherwise damaged.

Fiber optic cables, if not protected, are susceptible to various types of damage. These include:

Abrasion of the protective covering

Repetitive flexing of unsupported cable lengths

Breakage of fibers by tight bends

Compression of the fiber bundle

Physical damage from equipment operating in the area

Inadvertent damage from untrained personnel

The minimum bend radius of the fiber bundle is approximately 12 inches, or 30 mm. Do not bend tighter than this.

Always handle the fiber gently, and do not let it be compressed, abraded, or twisted.

As a rule, it is always best to mount the exposed cable in a cable tray, or other means of protecting the cable from damage.

There are various suppliers of cable trays. The one shown is manufactured by Panduit. Please find a supplier in your area, and protect the fiber optic cable in a suitable cable tray.



10 Ethernet Connection

The Analyzer PRO is shipped with a two-meter length of Ethernet communication cable, wired into the instrument and tie-wrapped in place. Do not remove the tie wraps or attempt to change the cable. The cable should last the life of the Analyzer PRO Instrument.

The cable type is as follows:

- Category 5e, SF/UTP Patch 4P
- IEC 61156-6 LSHT (or equivalent)

The exposed end of the Ethernet cable has an RJ-45 plug like that shown in the photo at right.

The exposed end should be connected to the LAN, and the connection should be shielded from wash-down, dirt, vibration, and tampering.

It is advisable to place the Analyzer PRO within the same “network neighborhood” as the computer on which Vision is installed. They should be under the same network “subnet mask”.

Because network setups vary dramatically from company to company, Metrohm cannot provide troubleshooting for a specific network. That is the responsibility of company IT and Network Support personnel.

As a rule, if the Analyzer PRO can communicate locally (whether through a local router or other means) then it is capable of network communication through a Local Area Network (LAN). Wide Area Networks (WAN) may pose problems due to different subnet masks, security issues, or firewalls between different parts of the network. Please consult your local support personnel for help with these issues.

It is very important to know if the connection cable is a “patch” or “crossover” type of cable. While the cables are usually marked in some manner, one way to verify is to view the ends of the cable together.

Patch cable:

When held with both ends as shown, conductors up, both ends of a patch cable will appear identical.

The “solid” orange, blue, green and brown will be in the same positions on each jack.

The striped wires may appear white, as in this photo, or the stripes may appear more clearly.

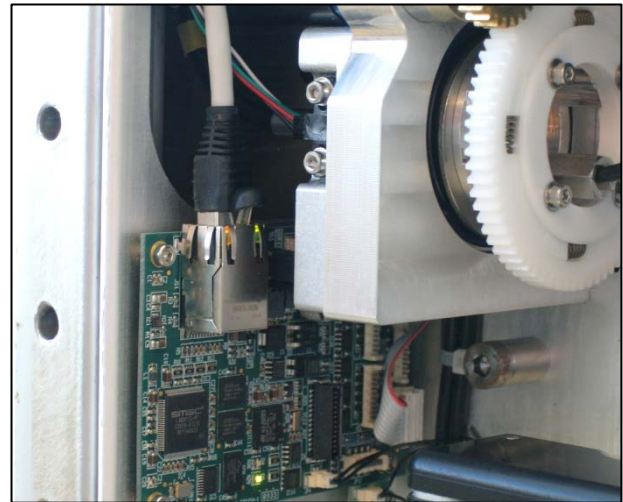

Crossover Cable:

When held with both ends as shown, conductors up, the wire patterns are different.

Note the left plug – the order of solid wires is orange, blue, green, and brown.

On the right plug, the order of solid wires is green, brown, orange, and blue.

On a crossover cable, the pairs are designed to “cross over” the signal when devices are hooked directly to each other, instead of through a network switch.

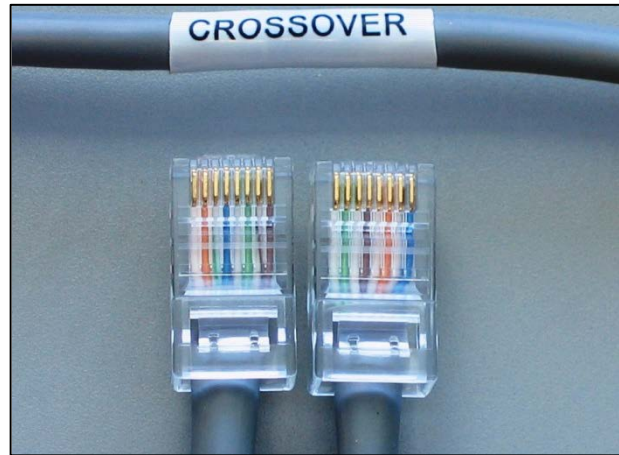

Devices are available with can plug into a cable and change the cable type from crossover to patch, or the other direction. In the latest networks, the type of cable may not matter, as the system sense the signal and corrects the pin signals as required. This is called “automatic MDI/MDI-X configuration”.

Because of the many variations in network design, capability, permissions, and administration, a full discussion is not possible in this manual. The field is very dynamic, and we recommend consultation with network personnel on these issues if problems arise.

11 Safety and Power-up

The Analyzer PRO is designed for safe operation in a process environment, and is well-sealed against dust, dirt, and wash-down. Do not open the housing or loosen any cable glands, as this may compromise the sealing of the unit.

It is allowable to release the mounting clamps which secure the unit, as the housing is sealed behind where the clamps mount. If removing the clamps, always use adequate safety precautions to prevent personal injury, or damage to the Analyzer PRO instrument.

Do not ever open the Analyzer PRO instrument with power applied, as hazardous voltages are present inside the instrument. Personal injury may result from contact with live power. Always use lockout procedures to avoid personal injury.

When dismantling the Analyzer PRO, avoid stressing or damaging the electrical lines in any way. As the instrument is moved, be sure there is adequate slack in the AC mains (power) and communications cables. If necessary, these may be disconnected at the external connecting points for each.

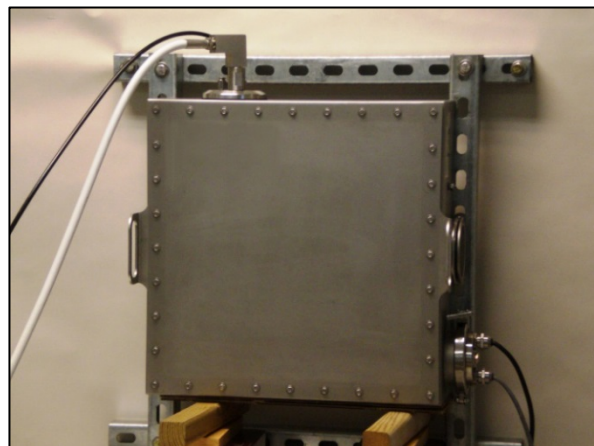

12 Connection to Vision Software

Analyzer PRO is designed to operate with Vision software. Vision requires a User ID and password for entry as a security measure. Each user must operate within a "Project" inside Vision. The procedure for creating a Project will be shown. Inside the Project, Vision uses a Data Collection Method (DCM) to communicate with the Analyzer PRO.

Please follow this procedure to connect:

1. Click on the Start icon, then click on Vision in the menu as shown.

Alternatively, if a Vision icon appears on the desktop, double-click it to open Vision.

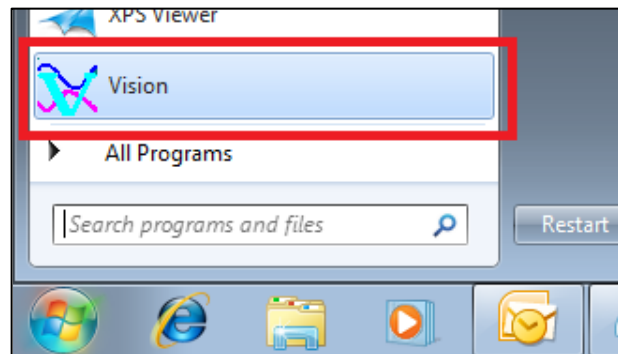

2. The Vision log-in box is shown. Type in the default User ID "NIRS" and then the default password, "NIRS".

Click "OK". Vision will open.

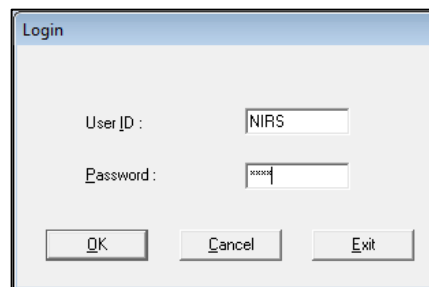

3. Vision prompts the user to create a new Project. Enter the name of the Project, using a logical name such as that shown, or a name related to the product being analyzed.

The name can be up to 16 characters, with no spaces. It may not contain characters like "/", "+", "*", or other such characters. The name will be shown in lower-case.

Location may be left empty, and Vision will place the Project database in the default Vision directory.

Click "OK".

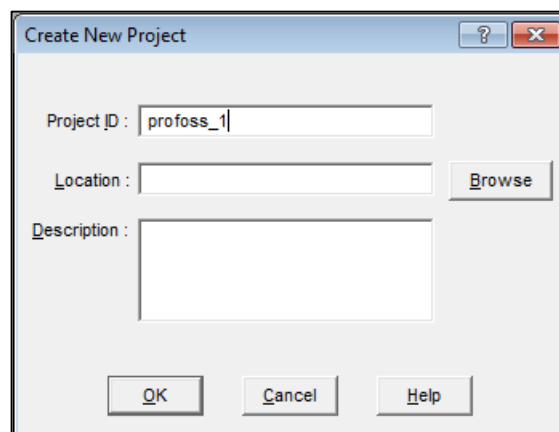

4. Vision asks to create a Project database as shown. If this location is acceptable, click "OK".

As a rule it is best to use the default location, unless there is an over-riding reason to use another location.

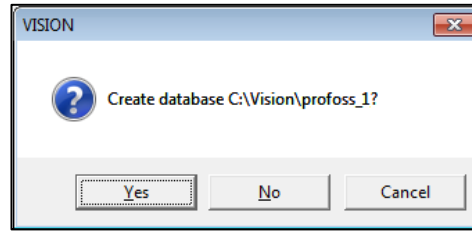

5. Vision opens a screen for configuration of data sources. This enables communication with the instrument through Vision.

Highlight "NIRSystems DDA Analyzer PRO Instrument Driver" and click "Configure".

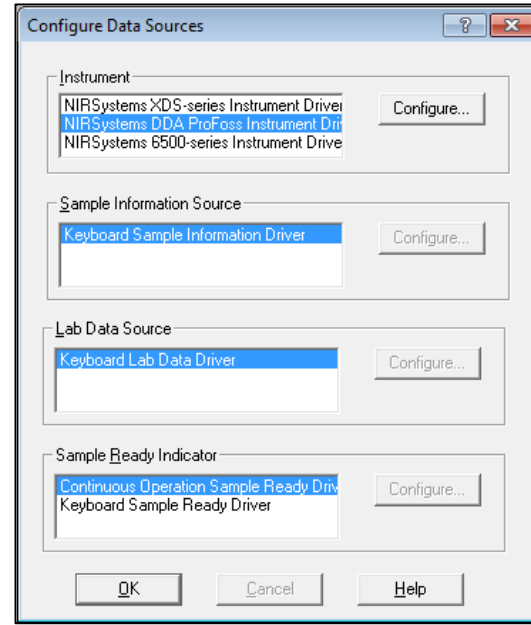

6. Select and highlight the instrument with the correct chassis ID number.

If there is only one instrument on the network, it will be shown by default, as shown at right.

Click "OK" to return to the previous screen. Then click "OK" again. This sets the communication channel to the Analyzer PRO instrument.

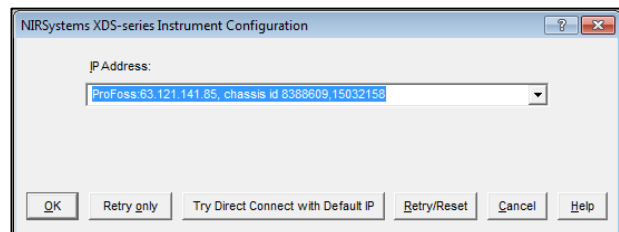

7. Vision prompts for connection to the instrument. Click on "Acquire new Data" to connect.

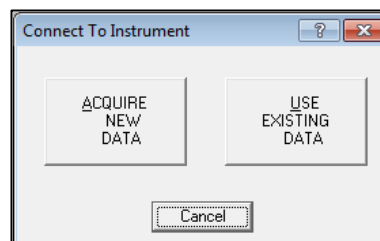

- The Analyzer PRO instrument runs an automatic self-checking routine, which appears as shown. No operator input is required.

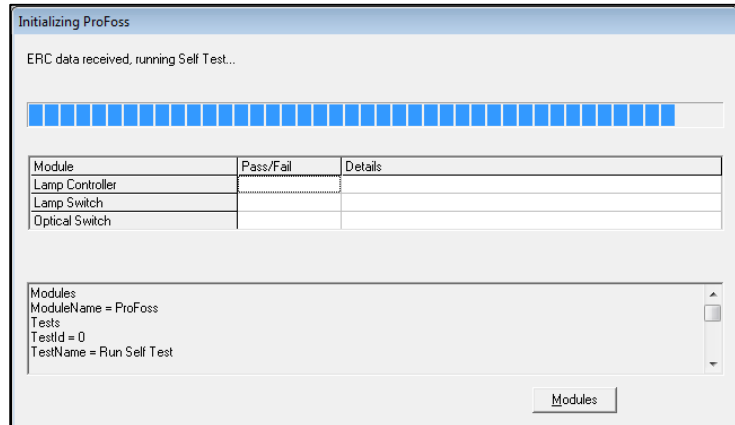

- When finished, the screen indicates successful testing. Click on "Close" to proceed.

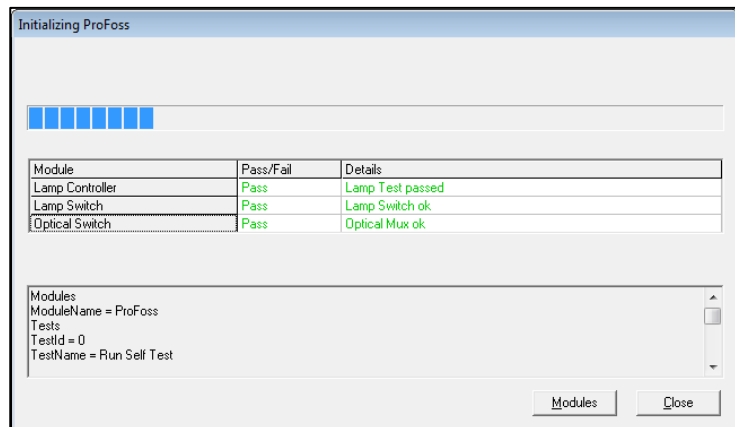

- Vision requests a valid Data Collection Method (DCM) in this screen. Since no DCM has been created yet, click on "New".

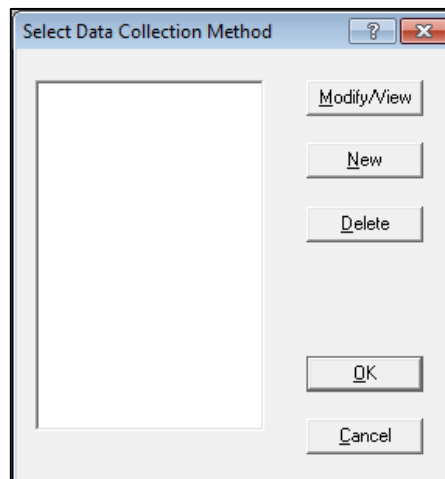

- The Profoss Analyzer sends its configuration to the Data Collection Method – this is a “Window Reflection” system, as shown in the Sampling system “Module” box.

The wavelength range is 1100-1650 nanometers. Reference Standardization is a default for this model, and the box is checked.

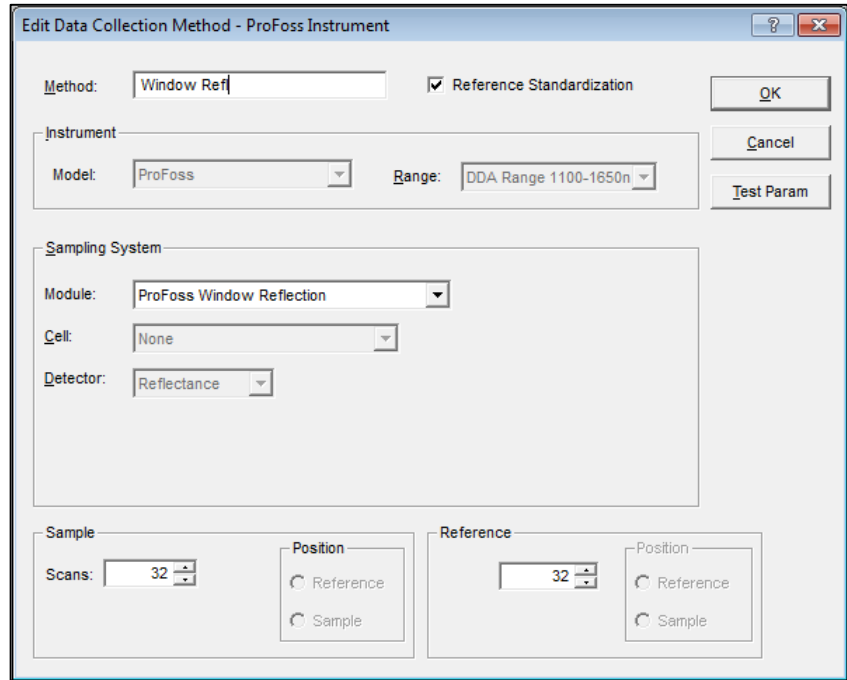

The “Method” name is empty when the DCM is displayed. Enter a name for the method. The name used here is “Window Refl”. Spaces are allowed in the DCM name.

Click “OK” when finished.

- Vision displays the selection box for the DCM. Click on the method just created, then click on “OK”.

You may hear some clicking noises from the Analyzer PRO instrument as it executes internal checks. These noises are normal.

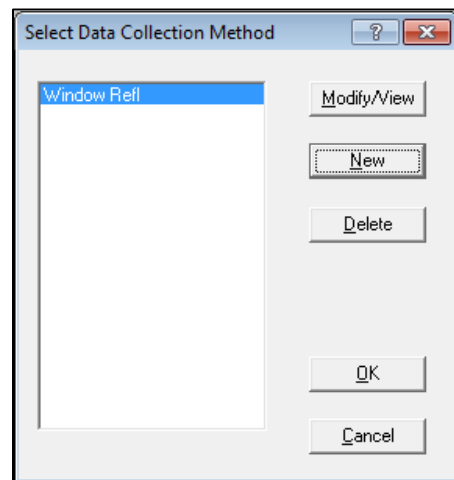

- Vision checks to verify that the instrument is stable. If the Analyzer PRO was just turned on, this may take some time, depending on ambient temperature.

Once the instrument is stabilized, this box is removed from the screen.

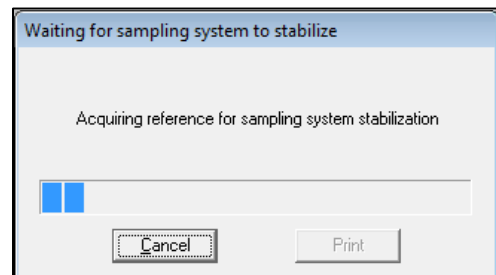

14. Vision displays the instrument configuration, so the user may confirm that this is the correct instrument.

This information is used to create a path in the Diagnostic Database.

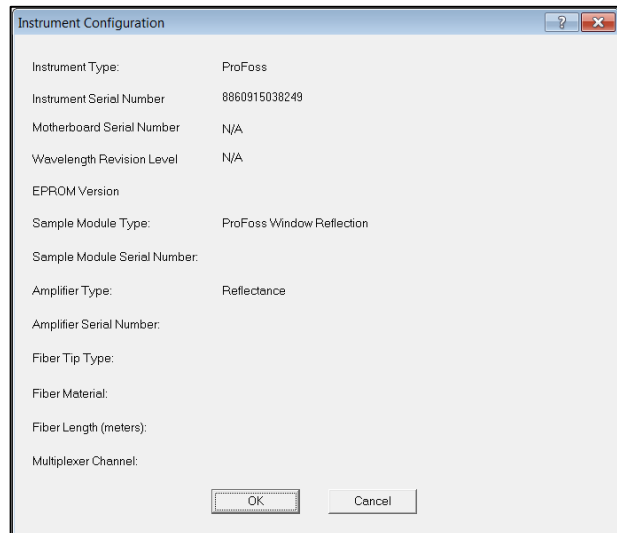

15. When the system is ready to run, the Diagnostics menu will become active.

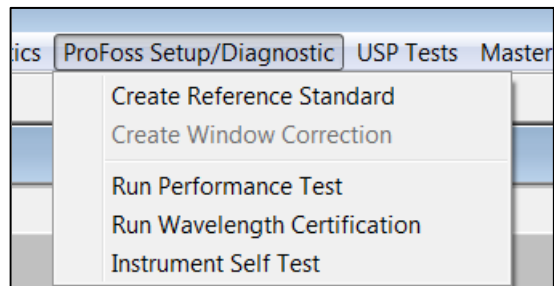

Please proceed to the section on Analyzer PRO Diagnostics.

13 Diagnostics

Diagnostics are provided to assure ongoing performance of the Analyzer PRO instrument. Upon each connection to the instrument, Self-Test is performed automatically. The instrument monitors itself, and will alert the operator in the event of malfunction.

It is wise to institute ongoing testing to monitor instrument performance and operation. The frequency for this testing depends upon application and usage, and should be set by the System Manager and other personnel who are preparing the system for use. This team of people will have the best information on frequency of use, and the need for ongoing testing.

The tests are quite similar for each instrument configuration; however there are small differences in how the standards are presented. Therefore this manual gives specific directions for each configuration. Find the configuration that will be used, and follow the directions accordingly.

Tests are described below.

13.1 Window Reflection

First, verify that the Data Collection Method is correctly set up.

1. Please verify that the Sampling System appears as shown below, in the area marked by the box.

There is no need to set "Cell" or Detector" as these selections default to the proper settings.

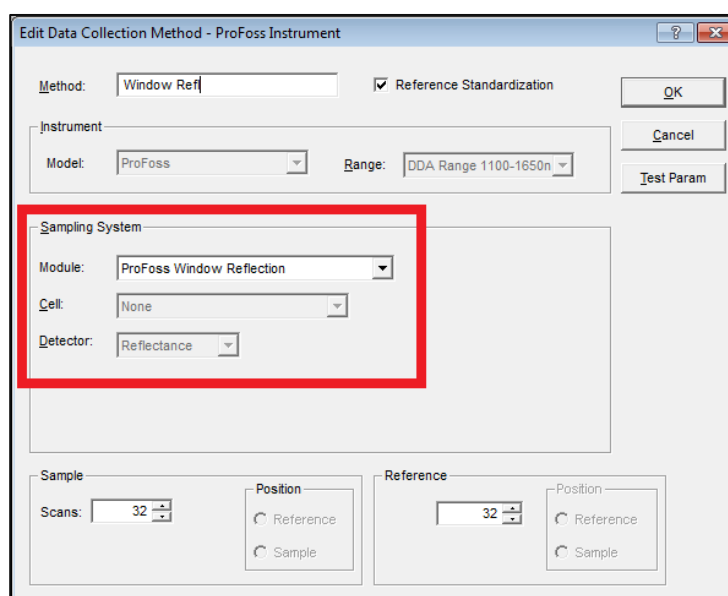

2. Click on OK if setting up the DCM, then select it in the "Select Data Collection Method" window as shown in the previous section of this manual.

If using the View DCM command, simply click on "Close".

13.1.1 Performance Test

It is wise to run Performance Test to verify that the instrument is fully warmed up and operating correctly. Follow these steps:

1. Click on “Analyzer PRO Setup/Diagnostic”, then “Run Performance Test”.

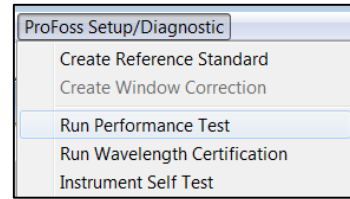

2. Vision displays the Instrument Configuration box. This information is used to set up the Diagnostic Database entries for this instrument. If correct, click on “OK”.

This box is shown upon each initial connection, and is not shown on subsequent diagnostic tests, as long as the instrument has remained connected to Vision.

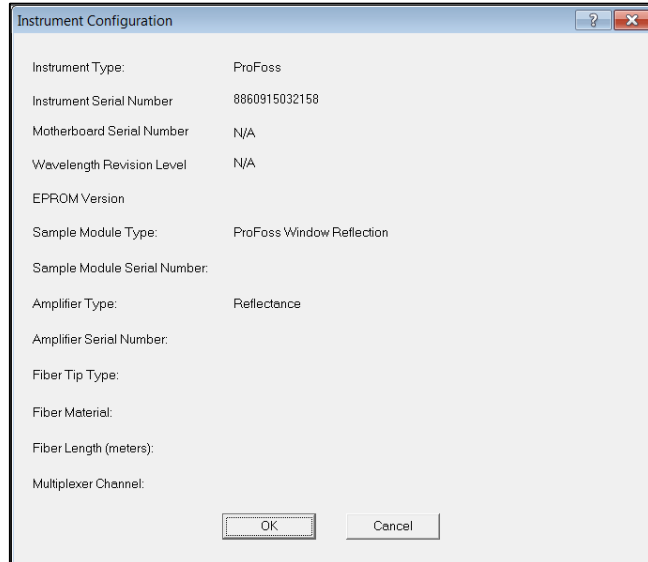

3. Vision asks which fiber should be used for the test. The test defaults to the Sample fiber. Do not click yet.

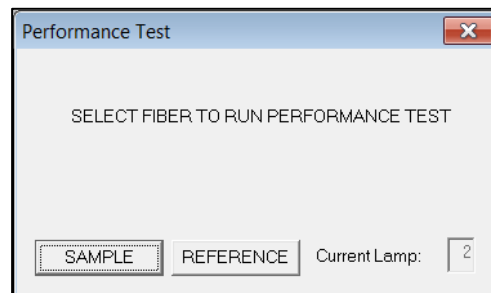

4. When testing the sample channel, always place the R80 standard on the sample window. Click on “Sample” to start the test.

Because of the large spot size, it is not necessary to orient the sample in any particular direction. Simply center it over the window as shown.

NOTE: We advise removing the standards when not in use. The intense light beam can warm the standards considerably, which will change their photometric response. Please place the standards on the window only for current testing, and remove them promptly when finished.



- When the test is finished, the split-screen display will appear as shown. (The test normally takes 9-10 minutes in this configuration.)

Double-click in the lower right quadrant to see the tabulated results.

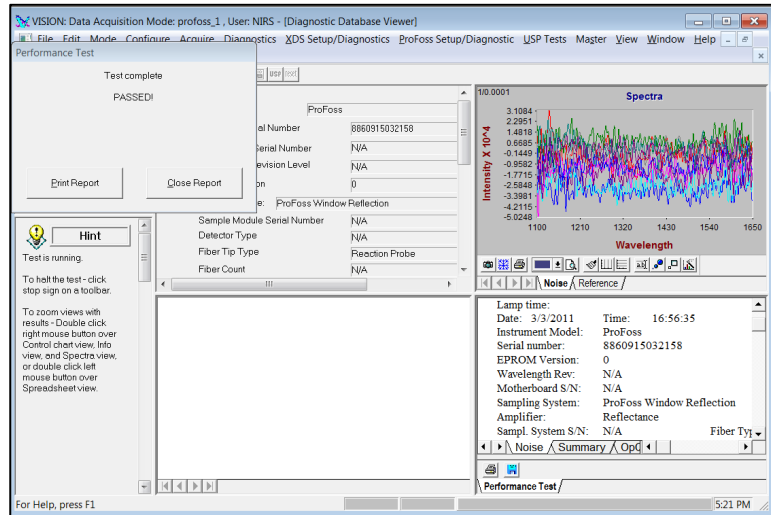

- The tabulated results show these items:

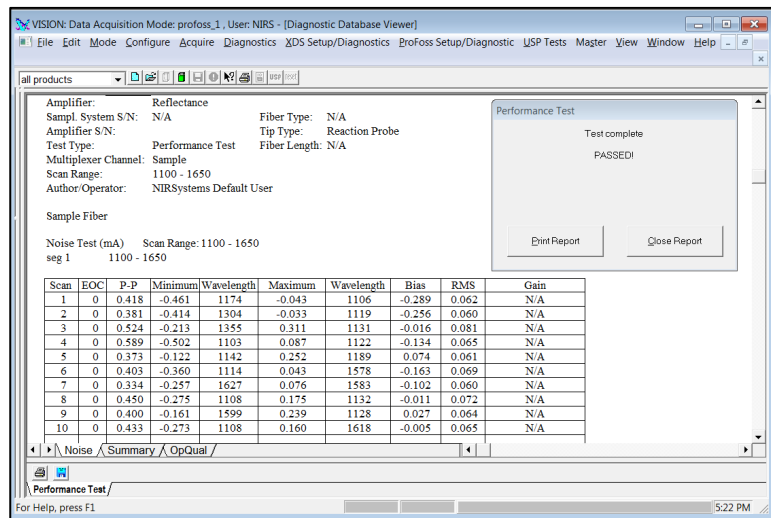

- Scan: 10 is the default value
- EOC: Errors on communication this will be "0" nearly all the time.
- P-P: Peak to Peak noise
- Minimum: Magnitude of lowest-going noise peak
- Wavelength: Location of negative peak
- Maximum: Magnitude of highest-going noise peak
- Bias: Baseline offset of noise scans
- RMS: Root-mean-square value of P-P
- Gain: Not used on this instrument

- The "OpQual" tab gives acceptance specifications, along with actual results and a "Yes/No" indicator to test status.

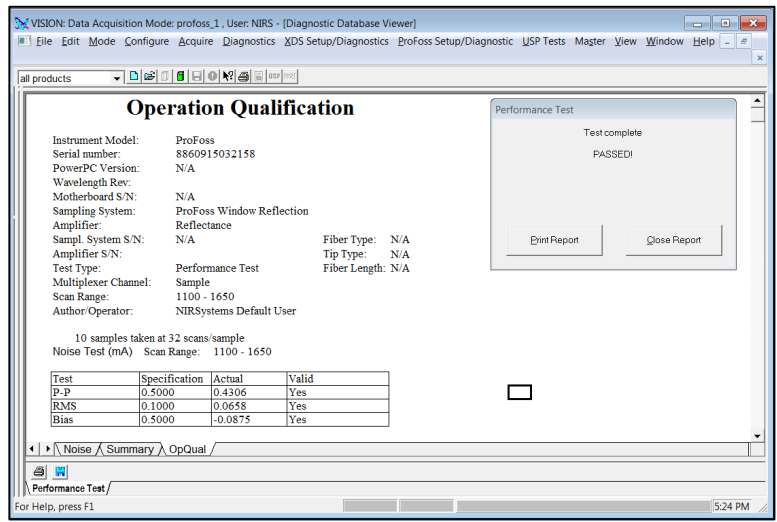

- If a printed copy is needed, click on "Print Report".

A copy is automatically saved to the Vision Diagnostic Database. Click on "Close Report" when finished.

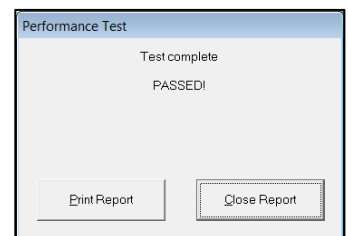

NOTE: We advise removing the standards from the sample window when not in use. The intense light beam can warm the standards considerably, which will change their photometric response. Please place the standards on the window only for current testing, and remove them promptly when finished.

13.1.2 Reference Standardization

Reference Standardization is a method to set the photometric scale of the instrument to a known, repeatable level. Ideally, the instrument reference scale should be set so that 100% reflectance is equivalent to zero (0) Absorbance. This facilitates transfer of models from one instrument to another of the same optical sampling geometry.

In practice, it is quite difficult to set the scale exactly, due to issues of cleanliness, temperature, and atmospheric influences. Fortunately, NIR instruments normally use mathematical and chemometric modeling methods that compensate for minor photometric scale differences between instruments.

- Click on "Analyzer PRO Setup/Diagnostic", then "Create Reference Standard".

This test is required to set the photometric scale to a known absorbance value.

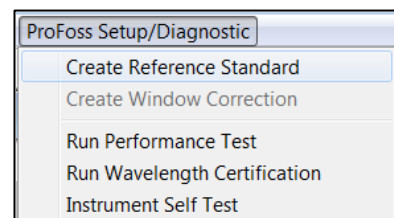

2. Vision shows this selection box, marked "Select ERC Correction File".

The term "ERC" stands for "External Reference Correction", which is another term for Reference Standardization.

Essentially, this is a method to mathematically correct the instrument reference to the equivalent of 100% reflectance.

From the CD or DVD drive, highlight the RSS1xxxx file, then click "Open".

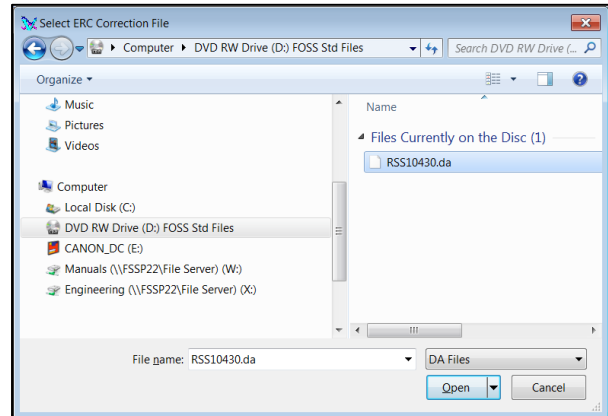

3. Vision prompts the user to place the 80% reflectance standard (R801xxxx) from the XC-1000 set over the sample window.

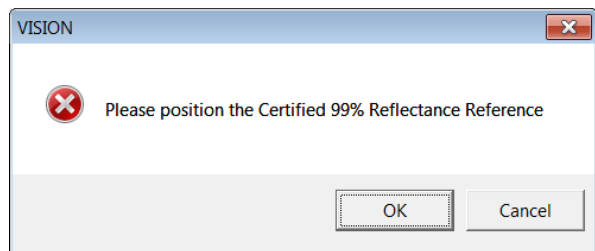

4. Click "OK" when the standard is in position.



5. Vision takes a scan of the internal instrument reference path. This may take several minutes. Some clicking of the optical switch assembly will be audible. Messages are shown at the lower left corner of the Vision screen indicating actions.

Click "OK" to have Vision plot the file spectrum of the Certified 80% Reflectance Reference standard, from the CD.

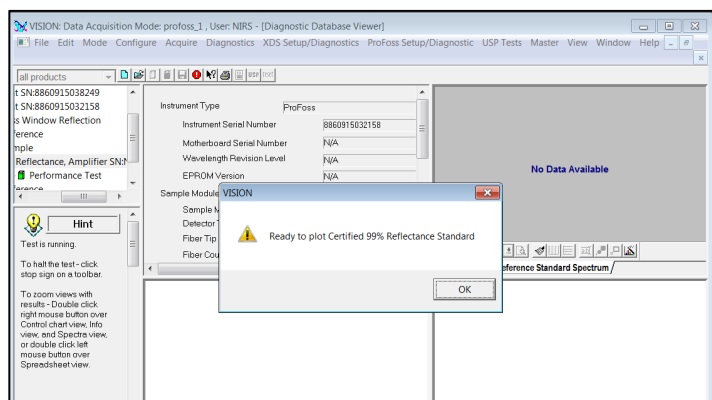

- Vision shows the spectrum of the certified 80% Reflectance Standard spectrum, plotted from 1100-1650nm.

Click "OK" to plot the spectrum of the correction.

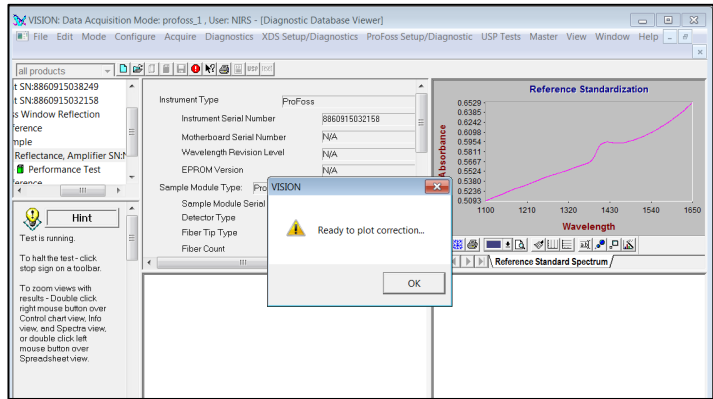

- Vision plots the correction spectrum in dark green. This correction spectrum will be applied to the internal reference.

Click "OK" to apply the correction.

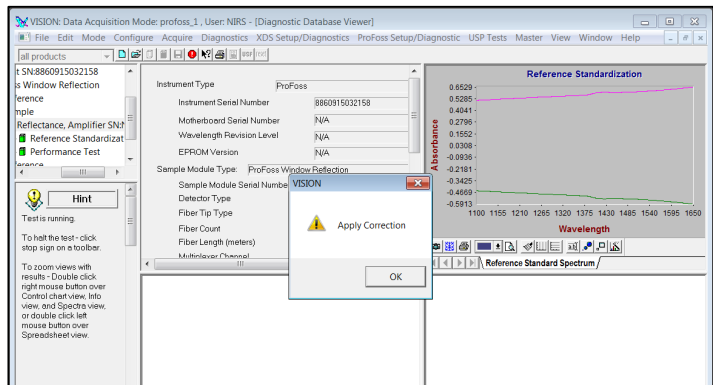

- Vision applies the correction, shown in purple.

Click "Yes" to save the ERC to the Diagnostic Database.

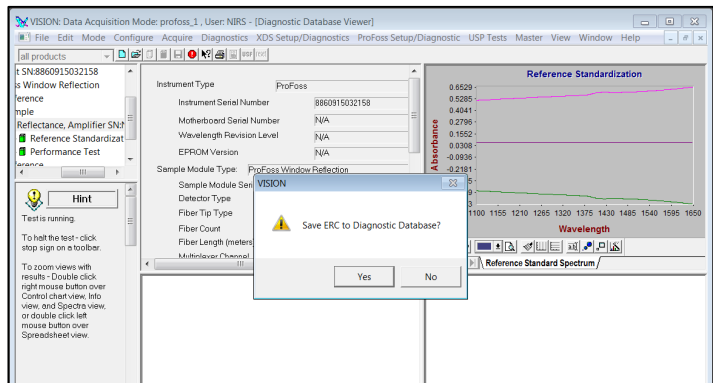

- Vision asks to upload the new ERC (Reference Standardization) to the Analyzer PRO instrument.

Click "Yes" to proceed.

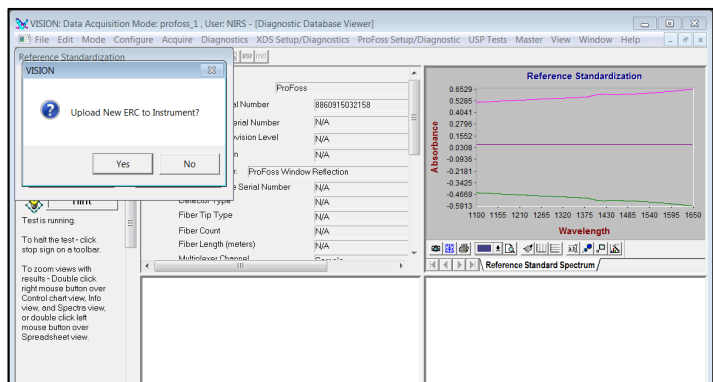

10. Vision loads the ERC (Reference Standardization) file to the instrument.

Click "Print Report" if verification is needed. Click "Close Report" when finished.

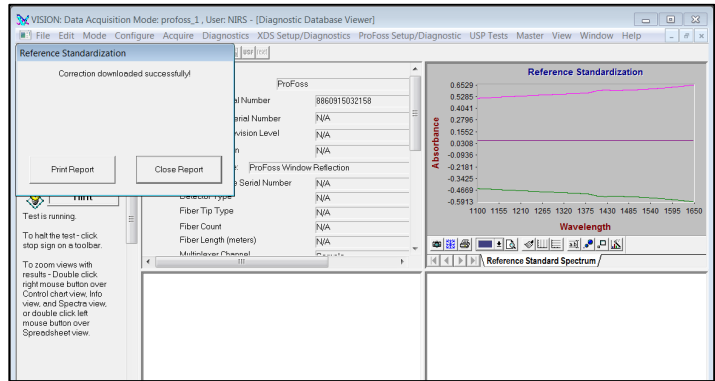

11. This enlarged plot shows the full Reference Standardization. Further explanation may help the user understand what is taking place.

The magenta plot at the top is a raw absorbance spectrum of the R80 standard, as measured through the instrument fiber paths.

The absorbance level is too high, due to fiber absorbance. This will be corrected using the certified spectrum of the R80 from the CD.

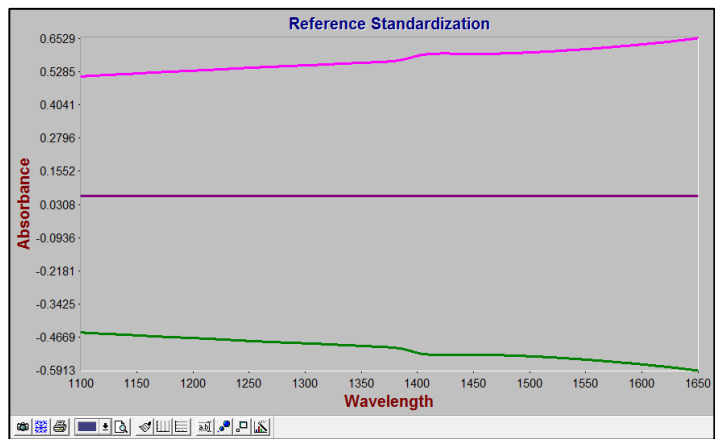

The dark green spectrum is correction required to read the certified 80% standard correctly on this instrument. By applying this correction, a true spectrum of the R80 will be displayed on this instrument.

The purple spectrum is the resulting, corrected spectrum of the R80 standard, after correction.

There is another mathematical correction which is applied, but that is not shown during Reference Standardization. The difference between the spectrum of the R80 standard and 100% reflectance is known, and is also applied to the reference as sample spectra are acquired. The net result is that sample spectra appear as if taken against a perfect 100% reflective background. Since this is done on each Analyzer PRO instrument, spectra and models should transfer with minimal baseline correction required.

When correcting the reference, there will always be slight correction differences due to fiber position, placement of the standard, temperature, dust, and other factors. Normally the correction will be good to within several hundredths of an absorbance unit, as illustrated above. Math treatments are used to correct for the resulting minor baseline effects.

13.1.3 Wavelength Certification

This test verifies that the wavelength scale of the Analyzer PRO meets parameters specified by the U.S. National Institute of Standards and Technology (N.I.S.T.) for NIR wavelength response using rare-earth standards.

1. Click on "Analyzer PRO Setup/Diagnostic", then "Run Wavelength Certification".

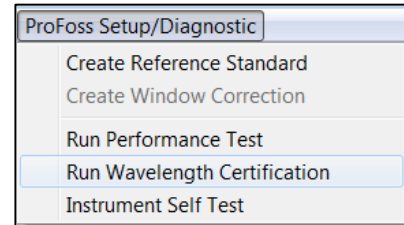

2. The default number of scans is 10. The default selection is "Wavelength Standard Analyzer PRO". Click "OK".

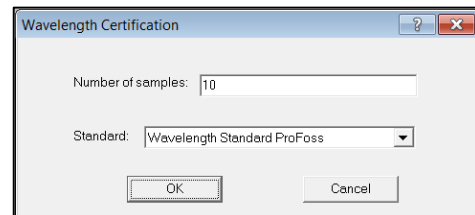

3. The Standards set contains a mini-CD with the standards file on it. Click on this file, then click "Open".

Vision initiates the test.

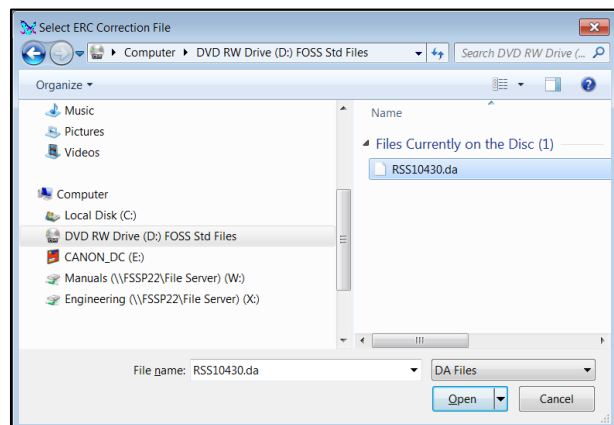

4. Vision begins taking an instrument reference spectrum.

5. Vision requests that the user place the wavelength standard onto the sample window.

Do not click "OK" yet.



6. Verify that the serial number of the standard is the same as that shown in the Vision prompt box.

Click "OK" when ready. Vision will start the test.



7. This test runs in about two minutes. Split-screen results appear as shown.
- Double-click on the lower right quadrant to see full tabulated results.

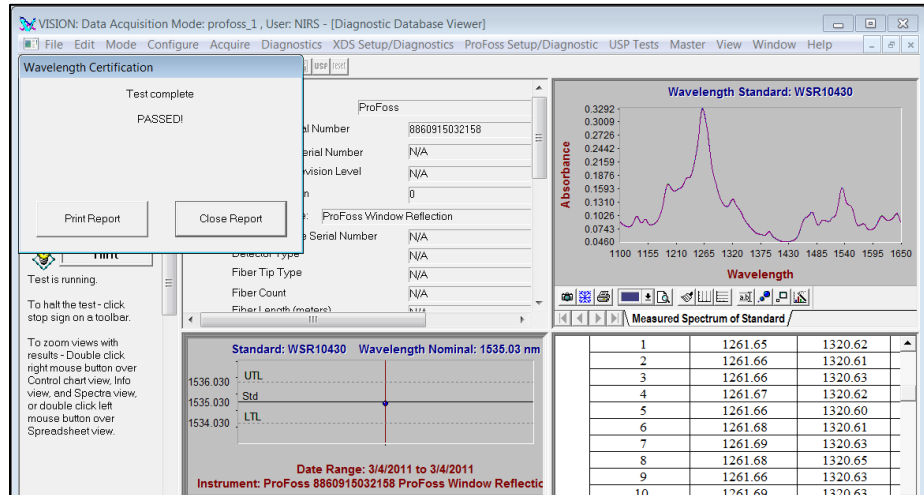

8. There are four wavelength peaks used, which serve to characterize the full wavelength scale of the instrument.

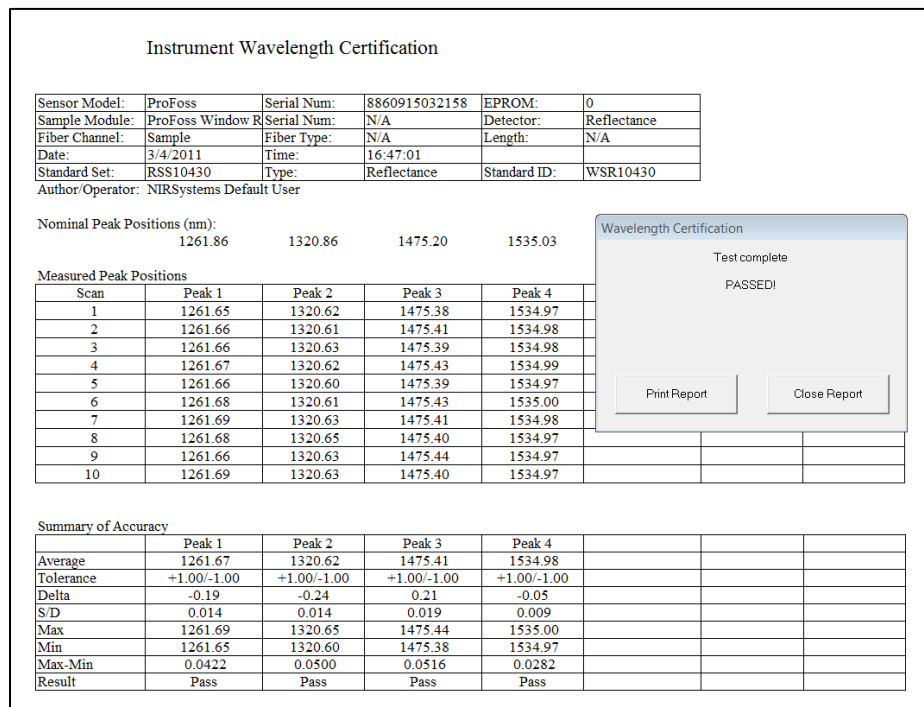

N.I.S.T. uncertainty is applied for rare-earth-type wavelength standards, shown as a tolerance of +/-1.0 nm.

The Pass result is shown at the bottom of this report for each wavelength peak tested.

9. If a printed copy is needed, click on "Print Report".

A copy is automatically saved to the Vision Diagnostic Database. Click on "Close Report" when finished.

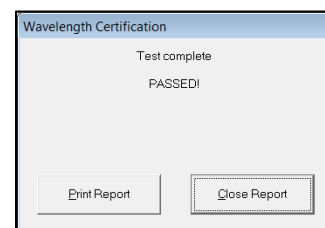

NOTE: We advise removing the standards from the sample window when not in use. The intense light beam can warm the standards considerably, which will change their wavelength response. Please place the standards on the window only for current testing, and remove them promptly when finished.

13.2 MicroBundle Fiber Optic Sensing

First, verify that the Data Collection Method is correctly set up.

1. Please verify that the Sampling System appears as shown below, in the area marked by the box.

Note that the drop-down menu shows three different types of probes which may be used. We will use the Interactance Reflectance Probe with Purge.

This probe is normally configured with a "Purge" time and a "Settle" time set in the DCM. The exact settings will depend upon a number of application factors, and are quite product-specific. Some experimentation may be required to find the best combinations.

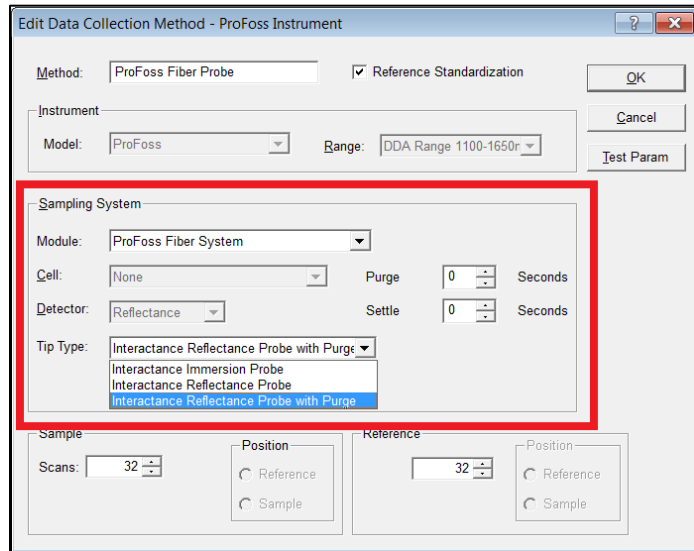

For our purposes now, we will leave the purge and settle settings at "0".

2. Click on OK if setting up the DCM, then select it in the "Select Data Collection Method" window as shown in the previous section of this manual.

If using the View DCM command, simply click on "Close".

13.2.1 Performance Test

It is wise to run Performance Test to verify that the instrument is fully warmed up and operating correctly.

For testing purposes, we suggest the probe end be securely clamped in place.

This photo shows a common testing clamp, which attaches to the side of a cart in the laboratory. Using this method, the fiber optic probe can be placed upright, and the reflectance standard cells are held securely in place by gravity. This avoids any gaps, or inaccuracy caused by too much compression.

The clamp is a Double-Buret Clamp, part number 05-779Q, available from Fisher Scientific. At the time of writing, the price is less than \$60 US.

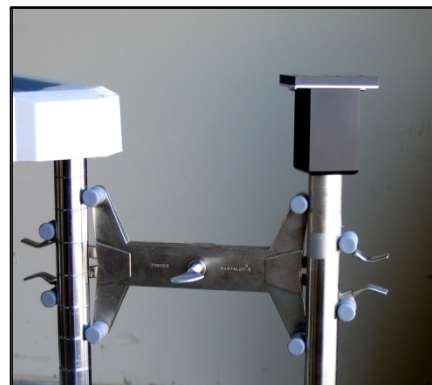

Follow these steps to run Performance Test:

1. Click on "Analyzer PRO Setup/Diagnostic", then "Run Performance Test".

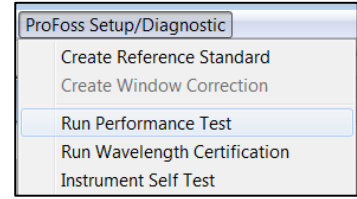

2. Vision displays the Instrument Configuration box. This information is used to set up the Diagnostic Database entries for this instrument.

If correct, click on "OK".

This box is shown upon each initial connection, and is not shown on subsequent diagnostic tests, as long as the instrument has remained connected to Vision.

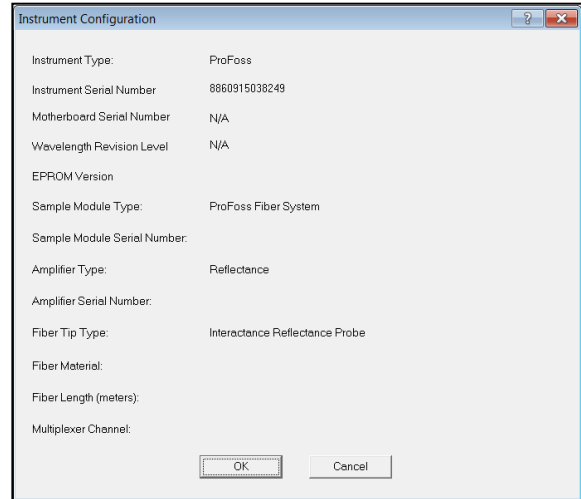

3. Vision asks which fiber should be used for the test. The test defaults to the Sample fiber. (Do not click yet.)

Be sure Reflectance probe – the one used for calibration – is on the fiber, and the reflectance standard is in place as shown in the photo.

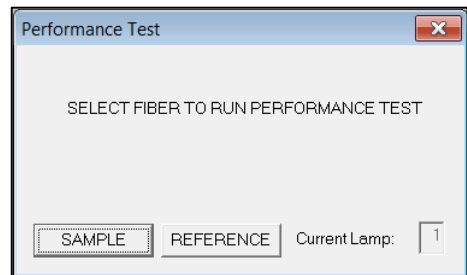

This shows the correct placement of the reflectance reference on the probe.

NOTE: the label may be on the top plate, instead of on the side.

Let gravity hold the reference in place – do not apply pressure, as this could compress the reference material and change its reflectivity.

As a precaution, always keep the probe window and the reflectance reference very clean. Do not allow dust, dirt, or liquids to contaminate the surface. Consistent spectral performance depends upon clean surfaces.



4. Click on "Sample" to start the test.

5. When the test is finished, the split-screen display will appear as shown. (The test normally takes 9-10 minutes in this configuration.)

Double-click in the lower right quadrant to see the tabulated results.

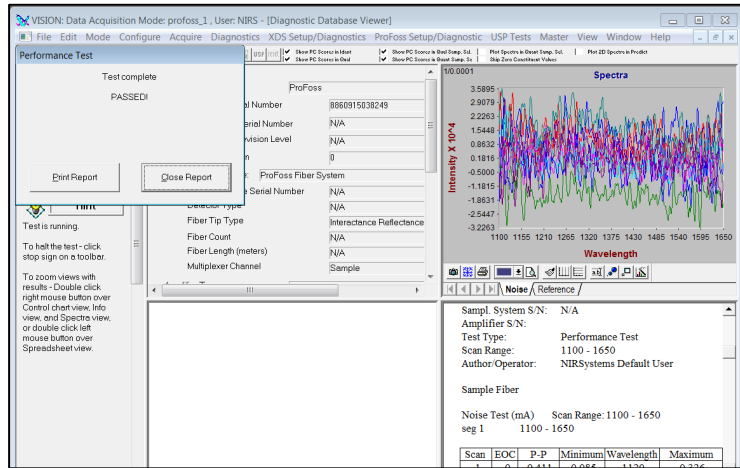

6. The tabulated results show these items:

Date: 2/8/2011 Time: 15:48:12
 Instrument Model: ProFoss
 Serial number: 8860915038249
 EPROM Version: 0
 Wavelength Rev: N/A
 Motherboard S/N: N/A
 Sampling System: ProFoss Fiber System
 Amplifier: Reflectance
 Sampl. System S/N: N/A
 Amplifier S/N:
 Test Type: Performance Test
 Scan Range: 1100 - 1650
 Author/Operator: NIRSystems Default User

Sample Fiber

Noise Test (mA) Scan Range: 1100 - 1650
 seg 1 1100 - 1650

Scan	EOC	P-P	Minimum	Wavelength	Maximum	Wavelength	Bias	RMS	Gain
1	0	0.411	-0.085	1120	0.326	1262	0.129	0.075	N/A
2	0	0.360	-0.107	1518	0.253	1119	0.014	0.061	N/A
3	0	0.385	-0.040	1443	0.345	1103	0.120	0.069	N/A
4	0	0.331	-0.152	1554	0.179	1215	0.007	0.057	N/A
5	0	0.424	-0.323	1593	0.101	1110	-0.154	0.060	N/A
6	0	0.376	-0.224	1646	0.152	1218	-0.007	0.070	N/A
7	0	0.397	-0.217	1570	0.180	1108	-0.033	0.071	N/A
8	0	0.396	-0.196	1123	0.200	1253	0.029	0.062	N/A
9	0	0.400	-0.041	1521	0.359	1107	0.169	0.074	N/A
10	0	0.488	-0.179	1104	0.308	1114	0.058	0.066	N/A

- Scan: 10 is the default value.
- EOC: Errors on communication – this will be “0” nearly all the time.
- P-P: Peak to Peak noise
- Minimum: Magnitude of lowest-going noise peak
- Wavelength: Location of negative peak
- Maximum: Magnitude of highest-going noise peak
- Bias: Baseline offset of noise scans
- RMS: Root-mean-square value of P-P
- Gain: Not used on this instrument

6. If a printed copy is needed, click on "Print Report".

A copy is automatically saved to the Vision Diagnostic Database. Click on "Close Report" when finished.

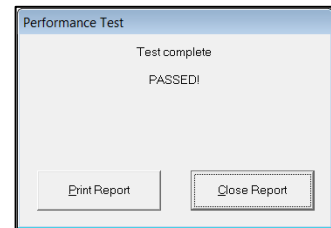

NOTE: We advise removing the standards from the sample window when not in use. The intense light beam can warm the standards considerably, which will change their photometric response. Please place the standards on the window only for current testing, and remove them promptly when finished.

13.2.2 Reference Standardization

Reference Standardization is a method to set the photometric scale of the instrument to a known, repeatable absorbance level. Ideally, the instrument reference scale should be set so that 100% reflectance is equivalent to zero (0) Absorbance. This facilitates transfer of models from one instrument to another of the same optical sampling geometry.

In practice, it is challenging to set the scale exactly, due to issues of cleanliness, temperature, and atmospheric influences. However, the scale can be set closely. Fortunately, NIR instruments normally use mathematical and chemometric modeling methods that compensate for minor photometric scale differences between instruments.

1. Click on "Analyzer PRO Setup/Diagnostic", then "Create Reference Standard".

This test is required to set the photometric scale to a known absorbance value.

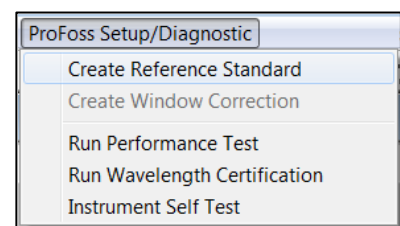

2. Vision shows this selection box, marked "Select ERC Correction File".

The term "ERC" stands for "External Reference Correction", which is another term for Reference Standardization.

Essentially, this is a method to mathematically correct the instrument reference to the equivalent of 100% reflectance.

Select the RSSP file, then click "Open".

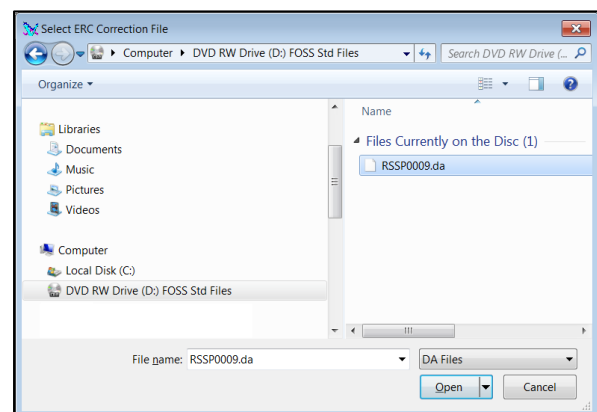

3. Vision takes a scan of the internal instrument reference path.

Click "OK" to have Vision plot the file spectrum of the Certified 99% Reflectance Reference standard, from the CD.

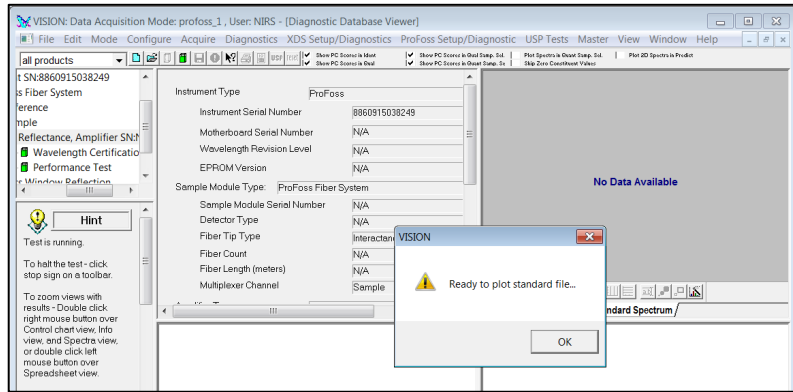

4. Vision plots the stored file of the Certified 99% Reflectance Reference standard.

Position the Certified 99% Reflectance Reference on the probe end, and click "OK".

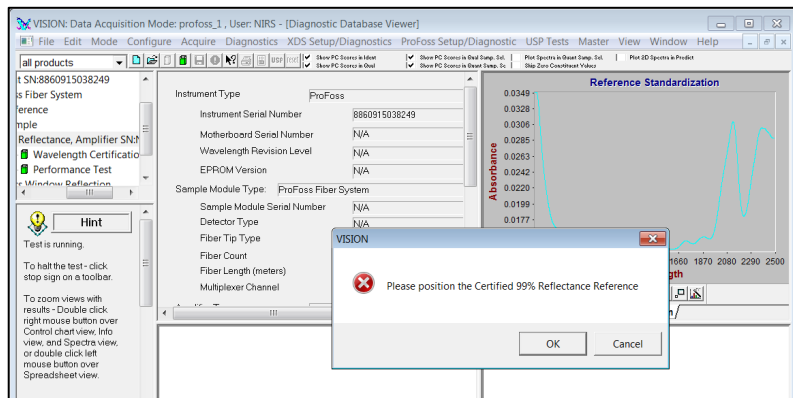

5. Vision prepares to scan the Certified 99% Reflectance Reference.

Click "OK". This may take several minutes to complete.

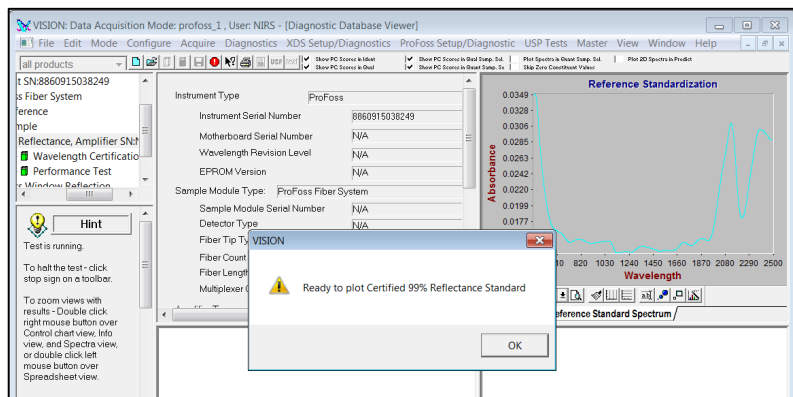

6. Vision plots the spectrum of the internal instrument reference in magenta.

Note that the wavelength scale is that of the instrument, 1100-1650nm. This is normal.

The overall plot is scaled from 400-2500 nm, the useful range of the Certified 99% Reflectance Standard.

Click on "OK" to proceed.

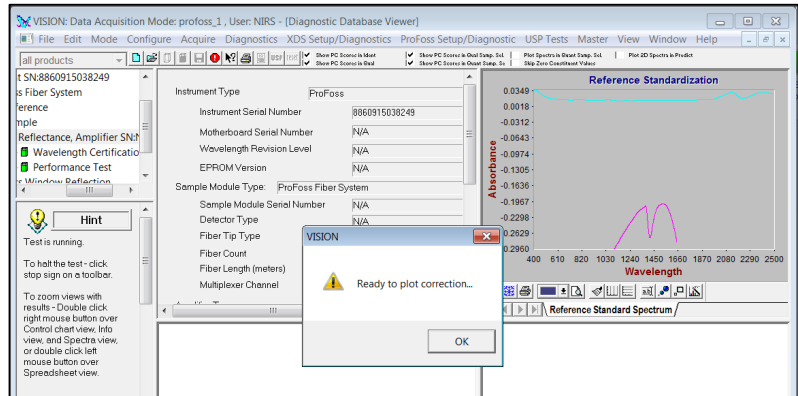

7. Vision calculates the correction needed to adjust the instrument reference as required. This is shown in green.

Click "OK" to apply the correction.

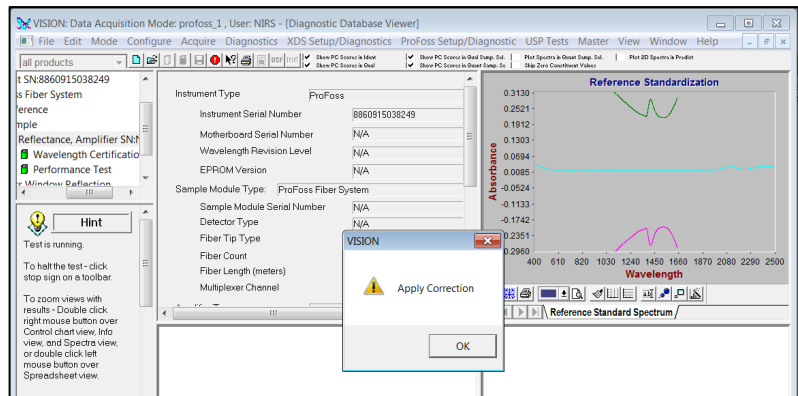

8. Vision asks to save the correction (called the "ERC") to the Diagnostic Database. Click "OK".

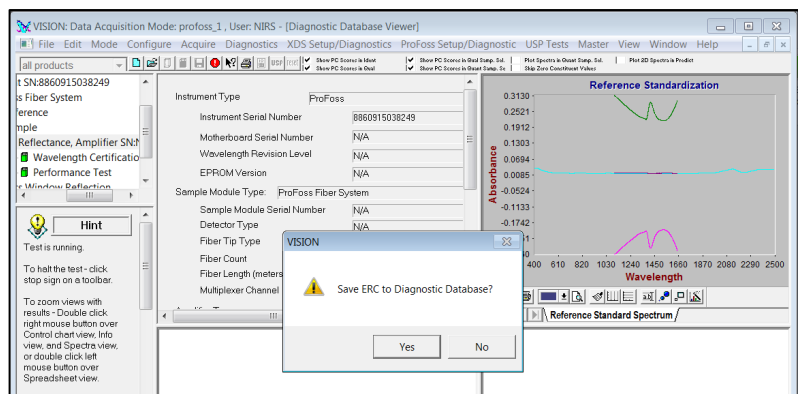

9. Vision asks to upload the ERC to the instrument for use when taking spectra. Click "OK".

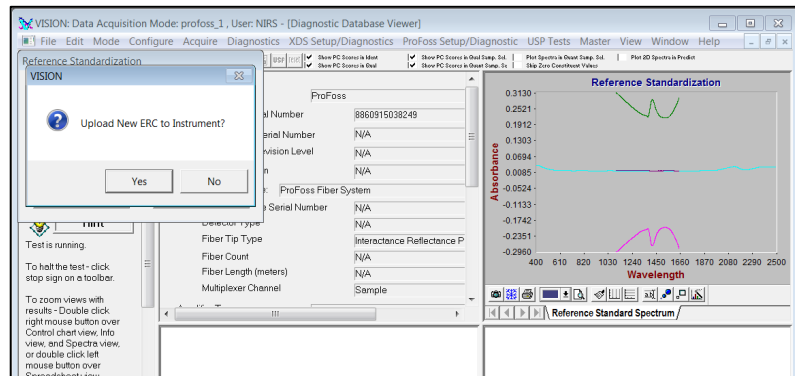

10. When finished, Vision indicates that the correction was properly loaded to the instrument. If a printed copy is needed, click on "Print Report".

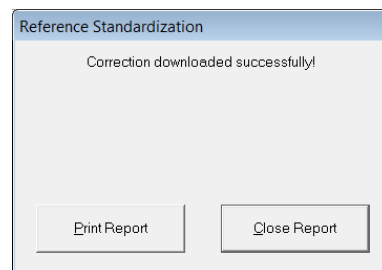

The plots on this diagram bear further explanation to help the user understand what is taking place.

The magenta plot at the bottom is a raw absorbance spectrum of the internal reference fiber of the instrument. This should not be used as a reference in this form, for two reasons:

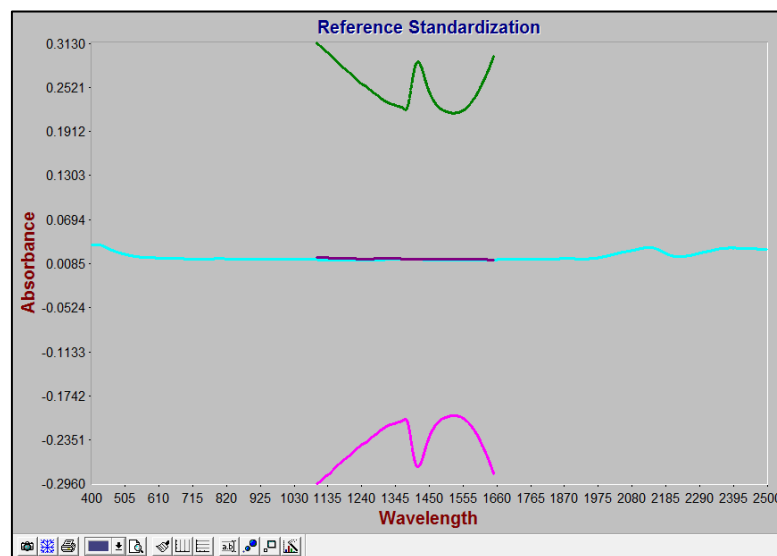

First, the absorbance is negative, which means the reference would appear artificially brighter than samples. Second, the spectral shape is not a flat line, and would impart unwanted artifacts into the sample spectrum. Correction is required.

The cyan (light blue) spectrum is the Certified 99% Reflectance Standard, as measured on a controlled, calibrated master spectrophotometer. This is close to 100% reflectance, though not exactly. By measuring on the master instrument, the difference between the instrument reference fiber and the Certified 99% Reflectance Standard is calculated, and is stored for correction purposes.

The correction between the Certified 99% Reflectance Standard and the instrument reference fiber is applied. This correction is the green spectrum at the top of the plot. When this correction is applied, the resulting spectrum is the purple line, overlaying the cyan plot of the Certified 99% Reflectance Reference.

Vision also applies the mathematical correction required to make the instrument reference read at

the 100% reflectance level, though this is not shown on the correction plot. By applying this mathematical correction, sample spectra appear as if taken using an ideal 100% reflective background reference.

When correcting the reference, there will always be slight correction differences due to fiber position, placement of the standard, temperature, dust, and other factors. Normally the correction will be good to within several hundredths of an absorbance unit, as illustrated above. Math treatments are used to correct for the resulting minor baseline effects.

NOTE: We advise removing the standards from the sample window when not in use. The intense light beam can warm the standards considerably, which will change their photometric response. Please place the standards on the window only for current testing, and remove them promptly when finished.

13.2.3 Wavelength Certification

This test verifies that the wavelength scale of the Analyzer PRO meets parameters specified by the U.S. National Institute of Standards and Technology (N.I.S.T.) for NIR wavelength response using rare-earth standards.

1. Click on "Analyzer PRO Setup/Diagnostic", then "Run Wavelength Certification".

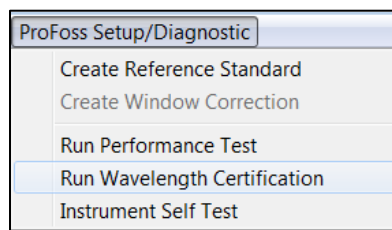

2. The default number of scans is 10. The default selection is "Wavelength Standard Analyzer PRO". Click "OK".

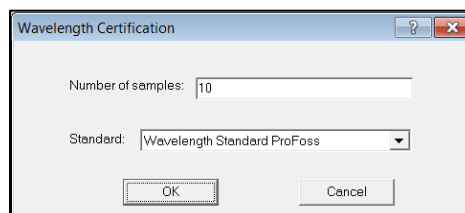

3. The XC-2400 Standards set contains a mini-CD with the standards file on it. Click on this file, then click "Open".

Vision initiates the test.

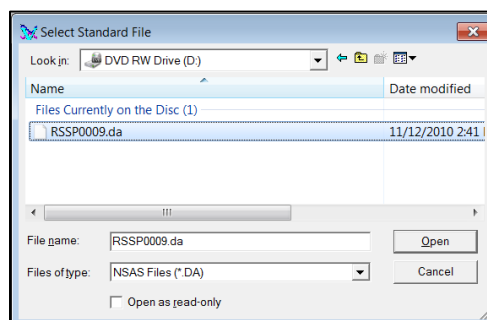

4. Vision requests that the user place the wavelength standard onto the probe. Do not click "OK" yet.

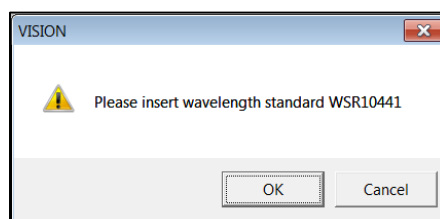

- Verify that the serial number of the standard is the same as that shown in the Vision prompt box. (A tie wrap may be present to hold the cup in place.)

Click "OK" when ready. Vision will start the test.



- This test runs in about two minutes. Tabular results appear as shown.

There are four wavelength peaks used, which serve to characterize the full wavelength scale of the instrument.

Instrument Wavelength Certification

Sensor Model:	ProFoss	Serial Num:	8860915038249	EPROM:	0
Sample Module:	ProFoss Fiber Syst	Serial Num:	N/A	Detector:	Reflectance
Fiber Channel:	Sample	Fiber Type:	N/A	Length:	N/A
Date:	2/8/2011	Time:	16:50:09		
Standard Set:	RSSP0009	Type:	Reflectance	Standard ID:	WSR10441

Author/Operator: NIRSystems Default User

Nominal Peak Positions (nm):
1261.86 1320.86 1475.20 1535.03

Measured Peak Positions

Scan	Peak 1	Peak 2	Peak 3	Peak 4
1	1260.96	1320.31	1475.16	1534.74
2	1260.97	1320.33	1475.15	1534.74
3	1260.95	1320.32	1475.16	1534.74
4	1260.97	1320.33	1475.18	1534.74
5	1260.97	1320.32	1475.16	1534.74
6	1260.97	1320.31	1475.16	1534.75
7	1260.98	1320.33	1475.17	1534.73
8	1260.97	1320.31	1475.17	1534.74
9	1260.97	1320.32	1475.16	1534.74
10	1260.95	1320.30	1475.15	1534.73

Summary of Accuracy

Average	Peak 1	Peak 2	Peak 3	Peak 4
1260.97	1320.32	1475.16	1534.74	

Wavelength Certification

Test complete
PASSED!

- If a printed copy is needed, click on "Print Report".

A copy is automatically saved to the Vision Diagnostic Database. Click on "Close Report" when finished.

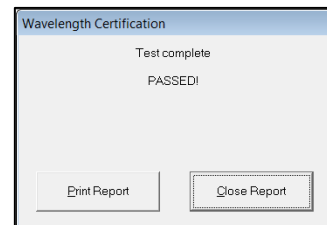

NOTE: We advise removing the standards from the sample window when not in use. The intense light beam can warm the standards considerably, which will change their wavelength response. Please place the standards on the window only for current testing, and remove them promptly when finished.

13.3 Direct Light Sampling

The Analyzer PRO Direct Light instrument setup is somewhat simpler than the others, as the sampling method does not lend itself to fine adjustments of "absolute" photometric scale or wavelength. The instrument is quite stable in both respects.

First, verify that the Data Collection Method is correctly set up. Please verify that the Sampling System appears as shown below, in the area marked by the box.

1. Please verify that the Sampling System appears as shown below, in the area marked by the box.

There is no need to set “Cell” or Detector” as these selections default to the proper settings.

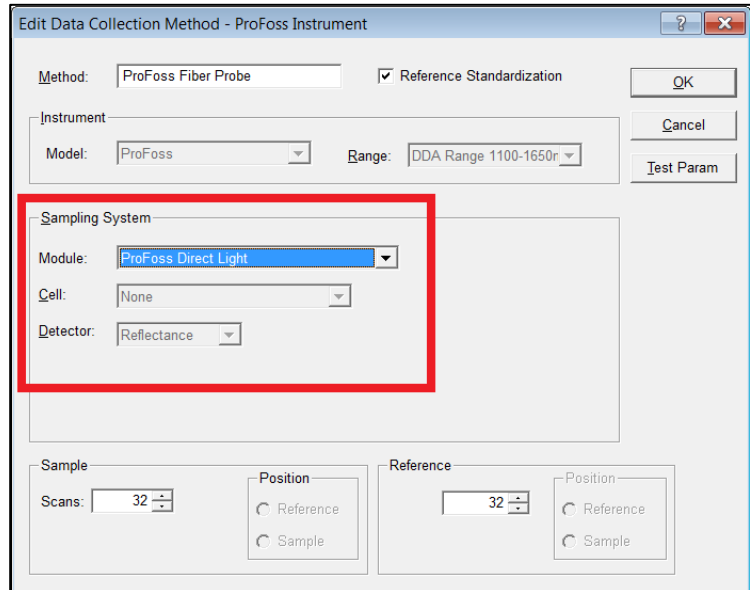

2. Verify that the instrument is correctly shown, and that the Sample Module Type is “Direct Light”.

Click “OK”.

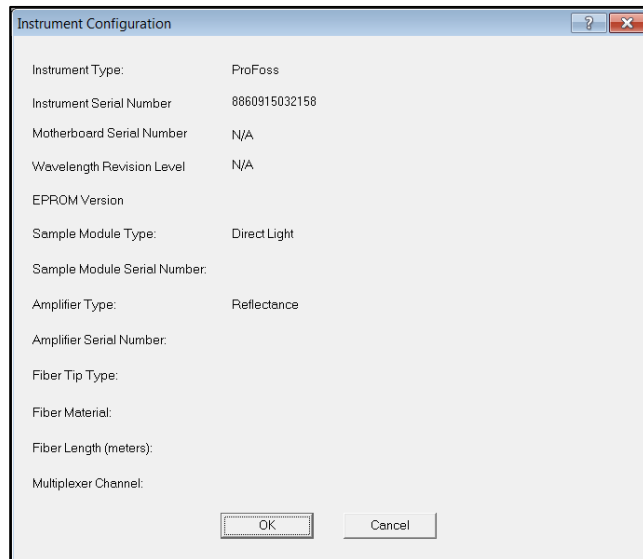

13.3.1 Performance Test

Follow these steps to run Performance Test:

1. Click on “Analyzer PRO Setup/Diagnostic”, then “Run Performance Test”.

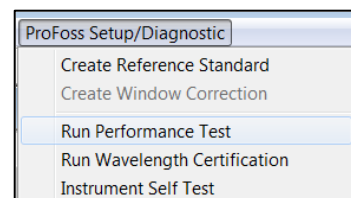

2. Vision displays the Instrument Configuration box. This information is used to set up the Diagnostic Database entries for this instrument. If correct, click on "OK".

This box is shown upon each initial connection, and is not shown on subsequent diagnostic tests, as long as the instrument has remained connected to Vision.

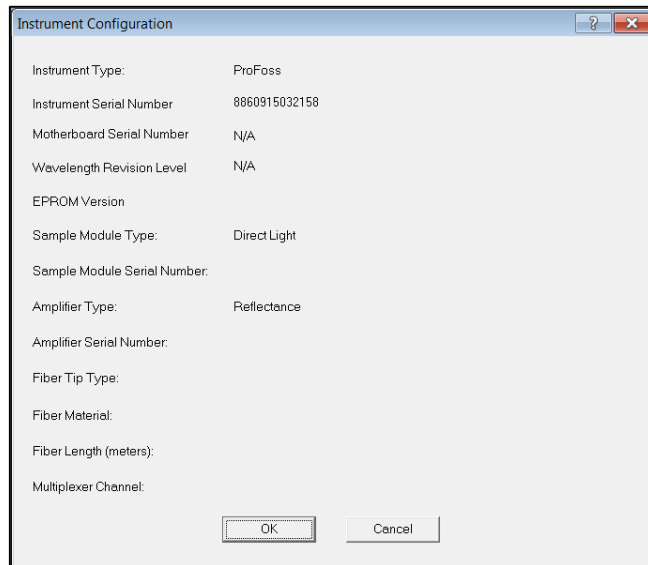

3. Vision asks which fiber should be used for the test. The test defaults to the Sample fiber. (Do not click yet.)

The Direct Light system should be tested in the "Reference" position. Click on "Reference" to begin the test. The system defaults to Lamp 1. You may hear the instrument making noises as the Optical Switch begins its operation. A note will be shown at the bottom of the Vision screen explaining each step.

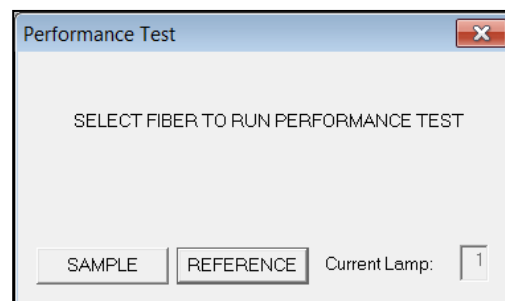

NOTE: While the "Sample" position could be used for Performance Test, this is not recommended with Direct Light. There are several reasons for this. First, a bright, 99% Spectralon sample without a quartz window should be used. Second, the distance should be 75mm (about 3") from the sample window. If the Spectralon is used frequently for Performance Testing, it will be very difficult to keep it clean, and this may impact other instrument adjustments and results.

As a precaution, always keep the probe window very clean. Do not allow dust, dirt, or liquids to contaminate the surface. Consistent spectral performance depends upon clean surfaces.

4. 4. When the test is finished, the split-screen display will appear as shown. (The test normally takes about 5 minutes in this configuration, on the Reference Channel.)

Double-click in the lower right quadrant to see the tabulated results.

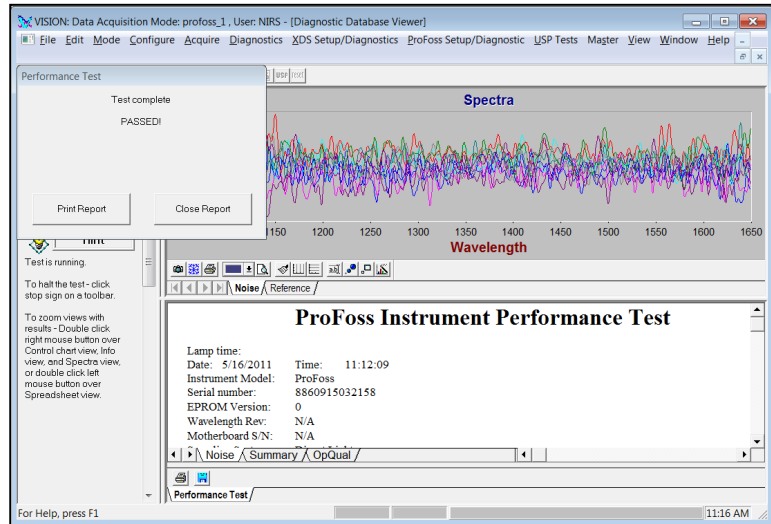

5. This is a typical set of Performance Test results for the Reference Channel. The tabulated results show these items:

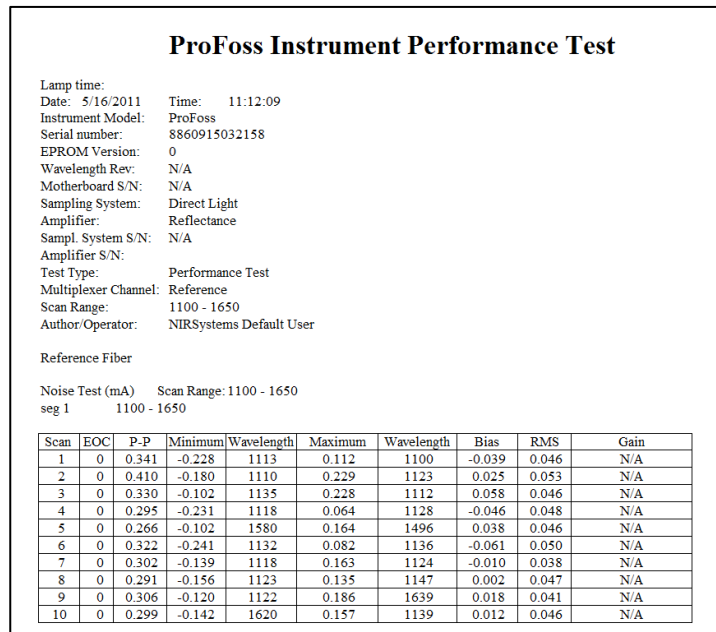

- Scan: 10 is the default value.
- EOC: Errors on communication – this will be “0” nearly all the time.
- P-P: Peak to Peak noise
- Minimum: Magnitude of lowest-going noise peak
- Wavelength: Location of negative peak
- Maximum: Magnitude of highest-going noise peak
- Bias: Baseline offset of noise scans
- RMS: Root-mean-square value of P-P
- Gain: Not used on this instrument

- To see the test results and acceptance specifications, click on the "OpQual" tab at the bottom of the screen. This is a typical result.

Operation Qualification

Instrument Model: ProFoss
 Serial number: 8860915032158
 PowerPC Version: N/A
 Wavelength Rev: N/A
 Motherboard S/N: N/A
 Sampling System: Direct Light
 Amplifier: Reflectance
 Sampl. System S/N: N/A
 Amplifier S/N: N/A
 Test Type: Performance Test
 Multiplexer Channel: Reference
 Scan Range: 1100 - 1650
 Author/Operator: NIRSystems Default User

10 samples taken at 32 scans/sample
 Noise Test (mA) Scan Range: 1100 - 1650

Test	Specification	Actual	Valid
P-P	0.6500	0.3161	Yes
RMS	0.0700	0.0461	Yes
Bias	0.2000	-0.0003	Yes

- If a printed copy is needed, click on "Print Report".

A copy is automatically saved to the Vision Diagnostic Database. Click on "Close Report" when finished.

Performance Test

Test complete
PASSED!

13.3.2 Reference Standardization (External Reference Correction)

Reference Standardization is a method to set the photometric scale of the instrument to a known, repeatable level. Ideally, the instrument reference scale should be set so that 100% reflectance is equivalent to zero (0) Absorbance. This facilitates transfer of models from one instrument to another of the same optical sampling geometry.

In the case of the Analyzer PRO Direct Light System this method is not practical for a variety of reasons, including operating distance, possible window reflections, temperature variations, and other optical factors. Instead, the Direct Light system is standardized on a special 99% Spectralon® standard. Once standardized, the system will maintain its settings for the life of the lamp, and should remain very stable. The Spectralon standard should be kept in a protected, clean location, so it will be ready when required at the next lamp change or major service interval.

Fortunately, NIR instruments normally use mathematical and chemometric modeling methods that compensate for minor photometric scale differences between instruments. This permits consistent spectral readings between like systems. The method for Direct Light is called "ERC" for External Reference Correction".

Because this function is performed at the factory, it is not covered in this manual. If you have a Analyzer PRO Direct Light System, please contact your local Metrohm office for more information on External Reference Correction.

14 Sampling

Once Vision Diagnostics have been performed, the user may take reference and sample spectra. In Data Acquisition, these actions are performed.

First, click on the Reference icon, which is a white cuvette.

When the Reference spectrum is finished, continue below.

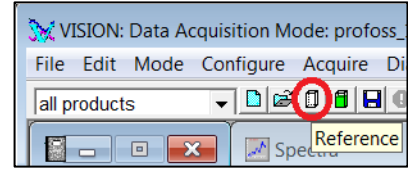

Next, click on the Sample icon, which is a green cuvette.

When the Sample spectrum is shown on screen, it may be saved.

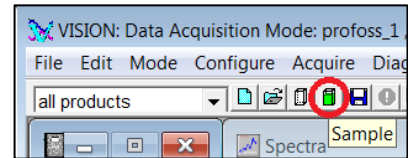

To save the sample spectrum, click on the blue diskette icon.

Vision will ask for product and sample names, and other information. Please see the Vision manual for full information on saving spectra.

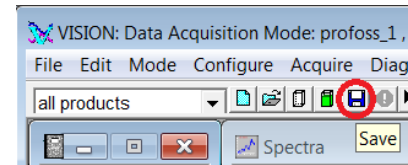

The green button on the housing is provided to take and store sample spectra in real time, from the process floor. This is useful when calibrating the system. In such cases, a "grab sample" may be taken for lab analysis, and a spectrum taken immediately, so that the lab analysis corresponds directly to the sample spectrum.

This sampling method makes the calibration data much more precise, and minimizes time lags and resulting changes to the product stream. It is important to note the time and date of the grab sample, so it can be correlated to the correct spectrum that will be stored.



When a sample is desired during Routine Analysis, press the green button, and Vision will take a sample spectrum. The spectrum will be stored in a Product called "***SaveKeyPressed***" and will be consecutively numbered. The acquisition time will be saved in the Properties box for that sample.

15 Standards and Approvals

The Analyzer PRO™ instrument is CE labeled and complies with the following directives:

- EMC Directive (2004/108/EC)
- Low Voltage Directive (LVD) (2006/95/EC)
- RoHS Directive (2002/95/EC) (Restriction of Hazardous Substances)
- Packaging and packing and waste Directive (94/62/EC)
- WEEE Directive (2002/96/EC) (Waste Electrical and Electronic Equipment)
- ATEX Directive, (94/9/EC), Zone 20 (EN 61241-1-2004 – Explosion safety for DUST-Protection by enclosure tD)
- IECEx, Zone 20 (IEC 61241-1-2004 – Explosion safety for DUST-Protection by enclosure tD)
- REACH Directive (1907/2006/EC) (Registration, Evaluation, Authorisation and Restriction of Chemicals)
- Developed and produced according to FOSS ISO approval, ISO 9001.